

# KB-29P TANKER

1/72 Scale

The first widescale American use of in-flight refueling took place in 1948 when a number of B-29s were converted to KB-29M tankers for the Strategic Air Command. Initially, the intent was to transfer fuel to other converted B-29s designated B-29MR (for receiver).

These aircraft used the British developed system of trailing lines, houses and a grapnel hook to catch and reel in the 3" fuel hose. When everything was in place, the tanker turned on the valves and refueled the awaiting receiver aircraft from its two 2,500 gallon fuel tanks carried in the bomb bay.

Later, a Boeing designed flying boom made in-flight-refueling much easier as the telescopic boom nozzle could be directed into the receiving receptacle. It was this system that was designated KB-29P and was used during the Korean War to refuel fighter aircraft on long ferry flights. The box illustration is based on the 1952 flight of seventy-five F-84G fighters flown from Texas to Misawa, Japan.

2113



DO NOT cement  
Ne pas coller  
Nicht kleben  
No pegar  
Non incollare  
Nao colar  
Niet kleven



Cut away  
Couper  
Scheiden  
Cortar  
Tagliare  
Cortar  
Snijden



Optional parts  
Choix  
Auswahlmöglichkeit  
Eleccion  
Scelta  
Opcao  
Keuze



3

Repeat operation  
Répéter l'opération  
Vorgang wiederholen  
Repitir la operacion  
Ripetere  
Repitir a operação  
Herhalen

**ACADEMY**  
**MINICRAFT**

1



2

Entire interior is CHROMATE GREEN FS34151, except where noted.

Seats are BLACK with TAN FS10260 cushions.

SILVER

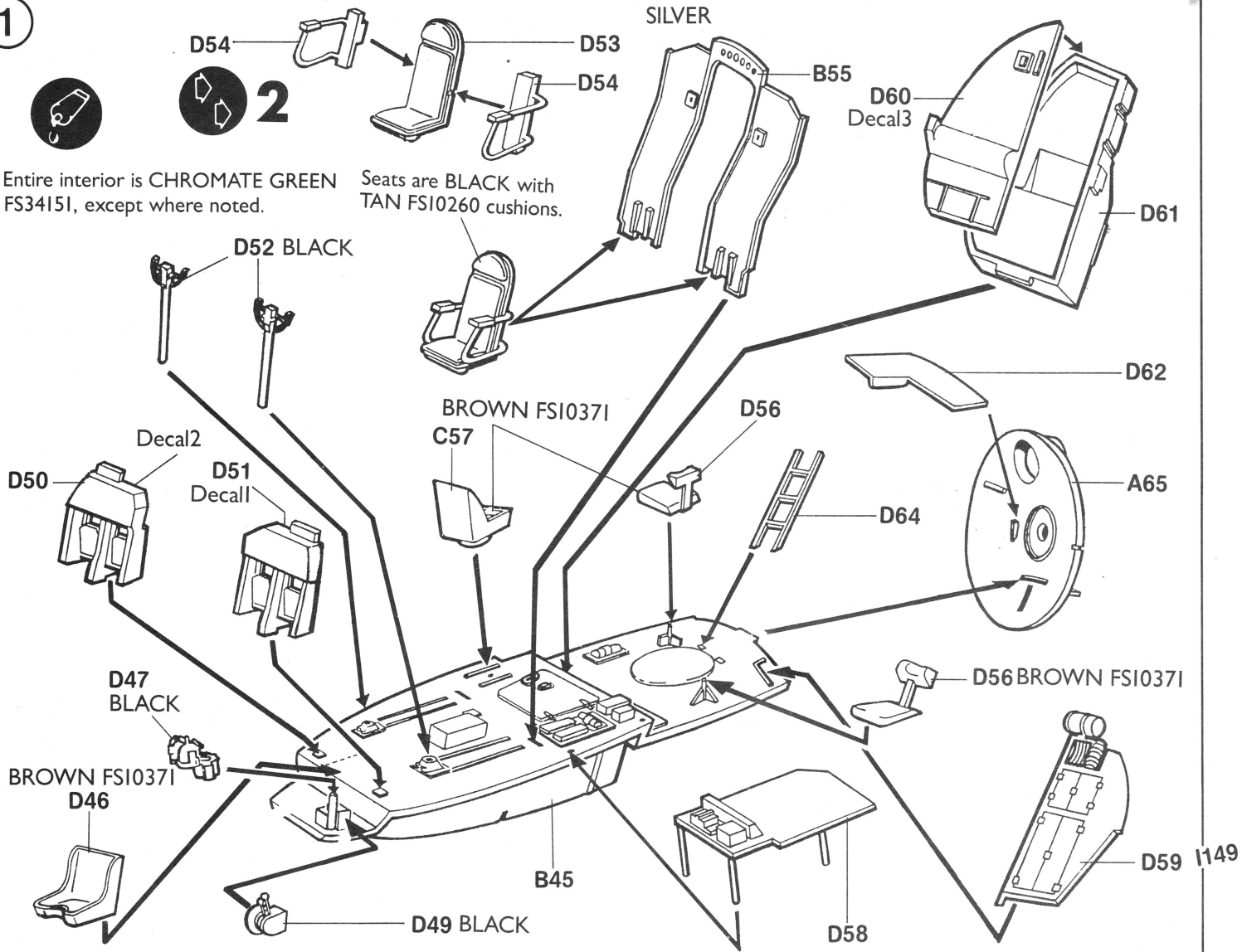

2



Entire interior is CHROMATE GREEN FS34151, except where noted.

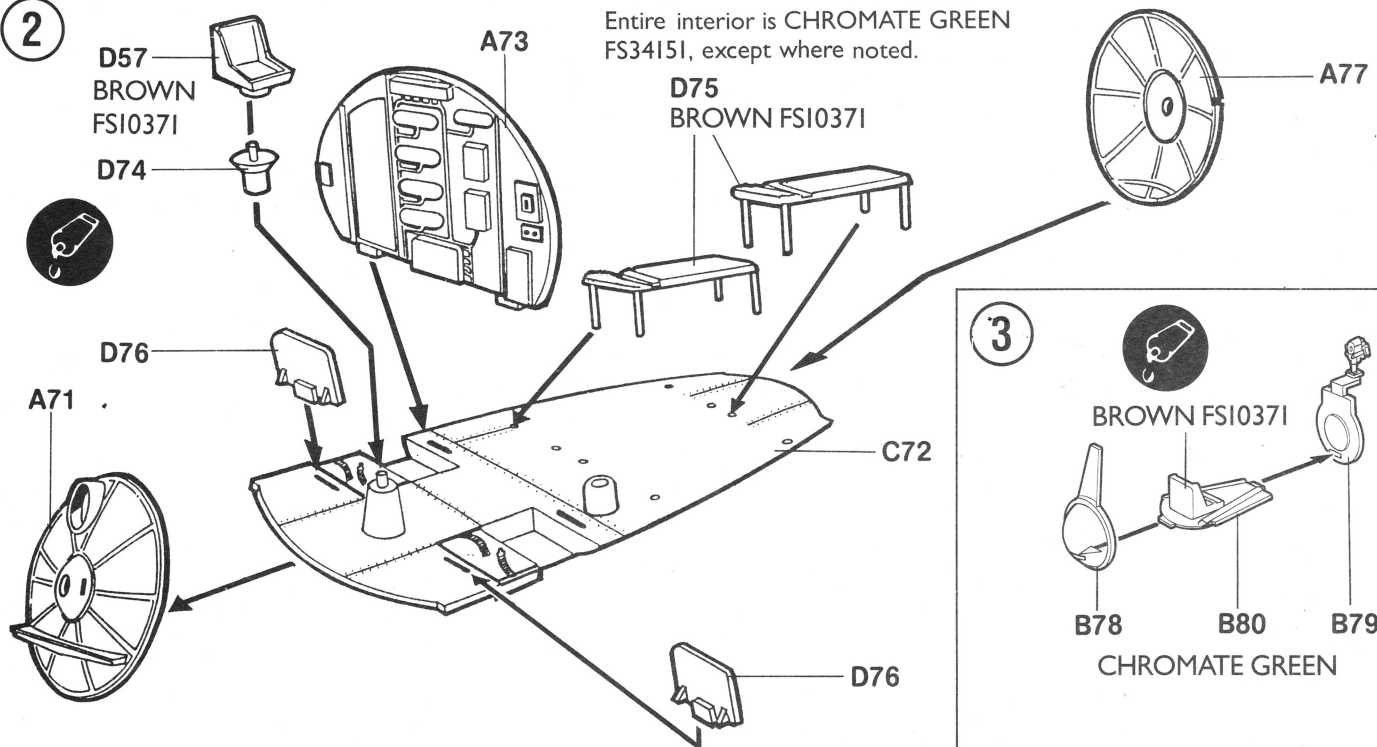

3



BROWN FS10371

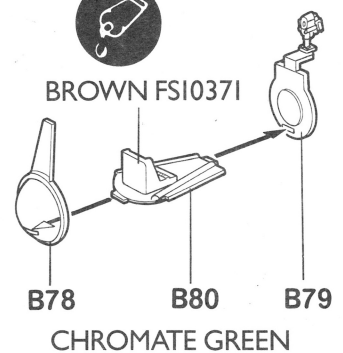

4

Entire interior is CHROMATE GREEN FS34151, except where noted.

Make two holes before the assembling fuselage halves.

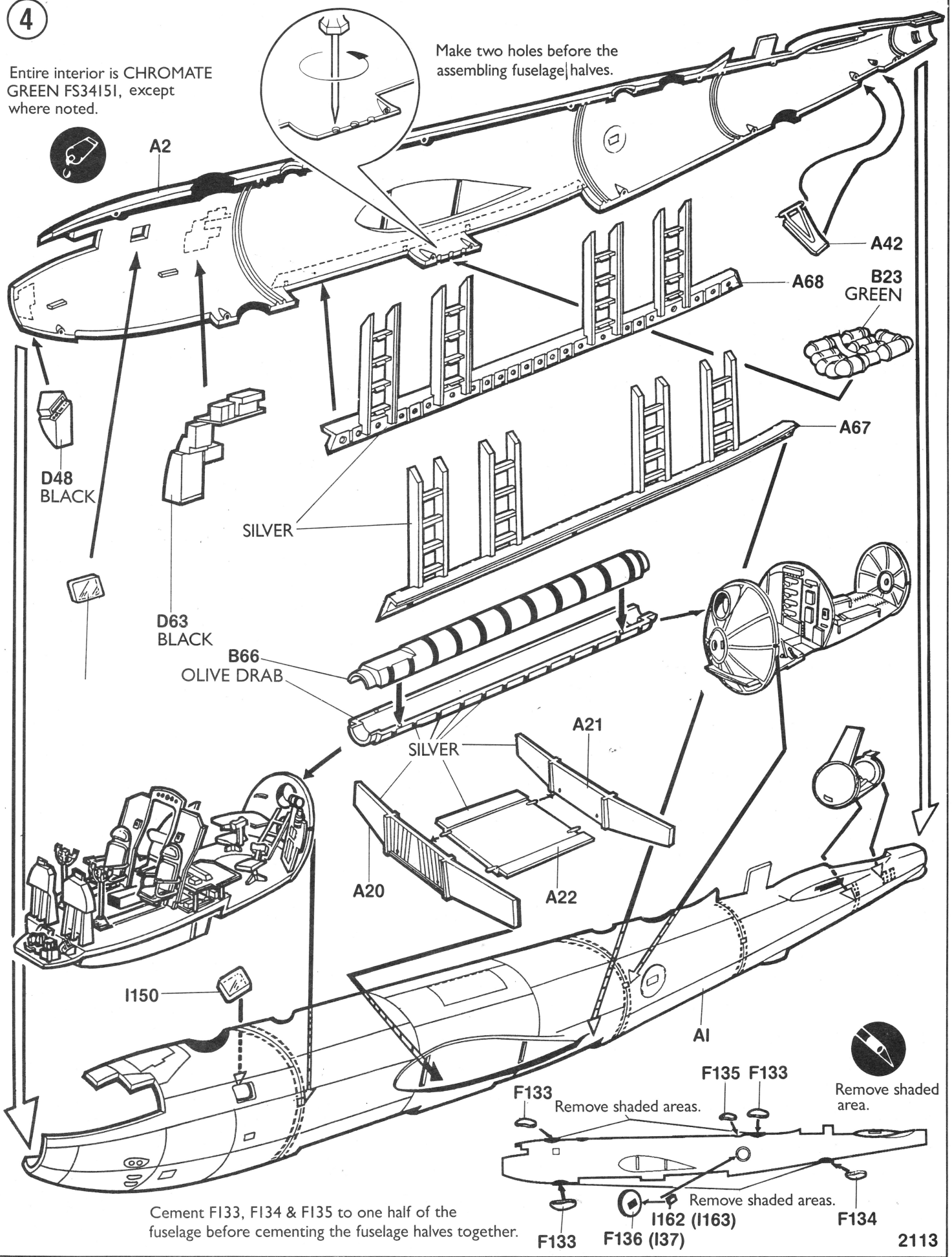

Cement F133, F134 & F135 to one half of the fuselage before cementing the fuselage halves together.

Remove shaded area.

Remove shaded areas.

2113

5

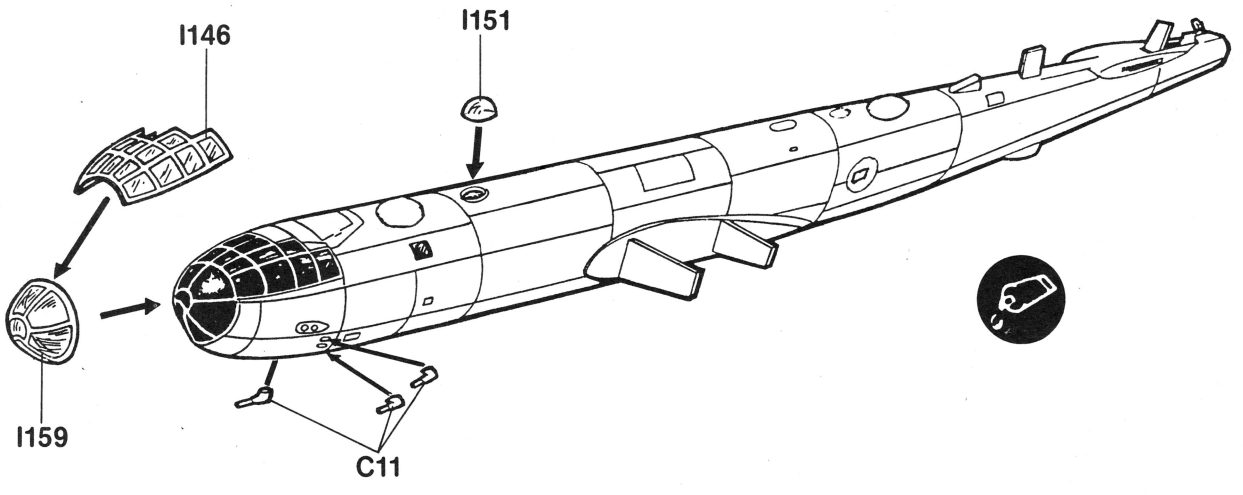

6

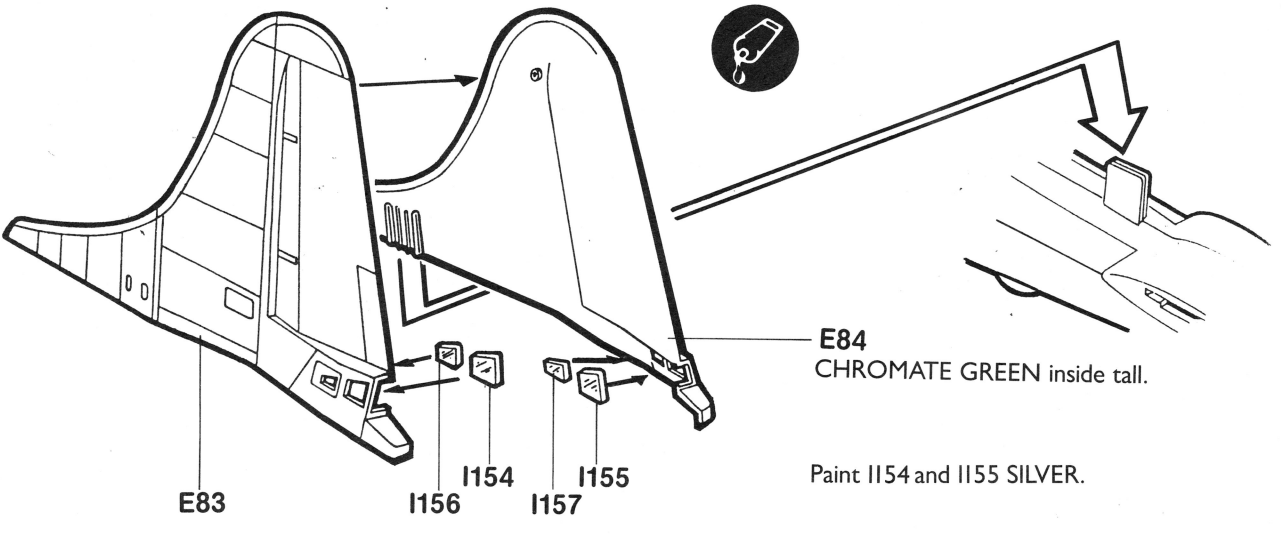

7

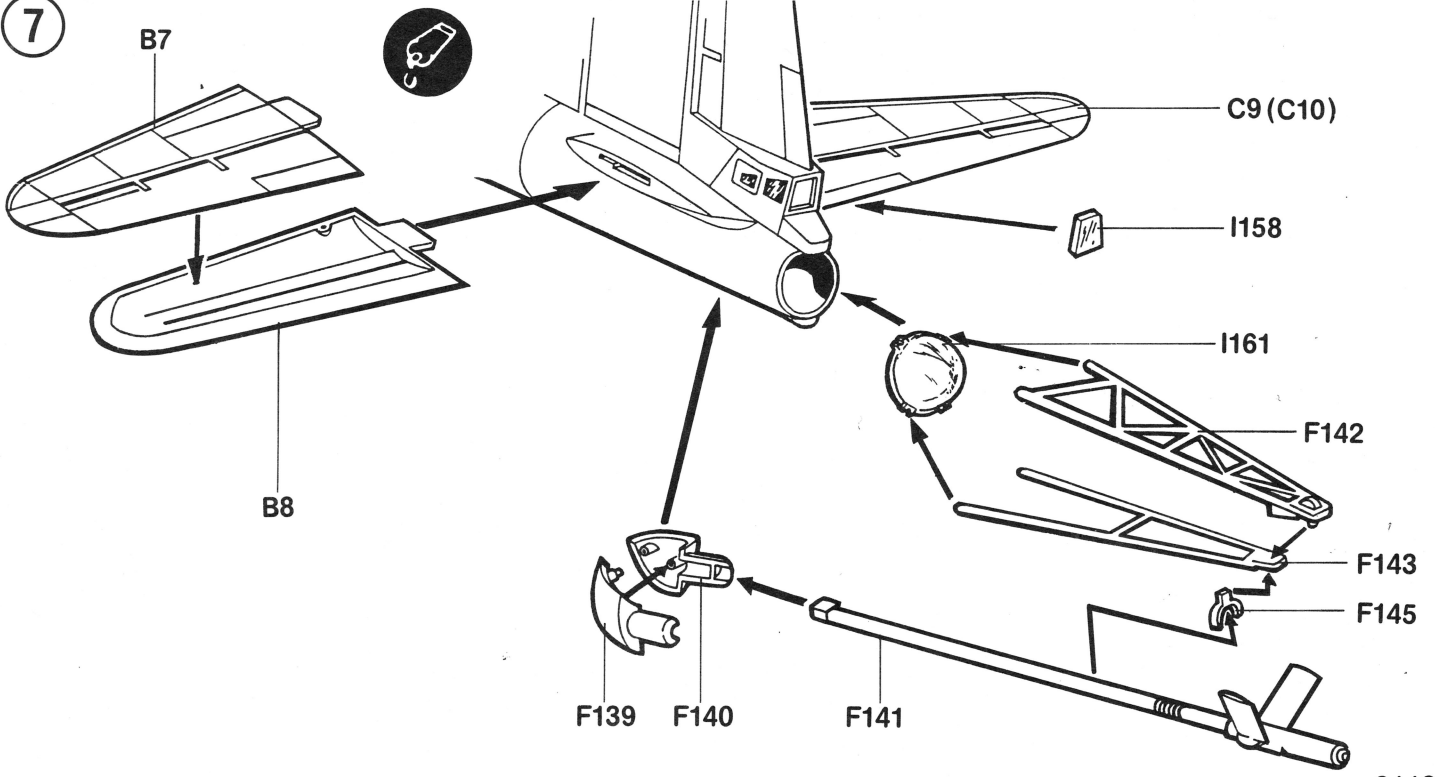

8

OUTBOARD

INBORAD

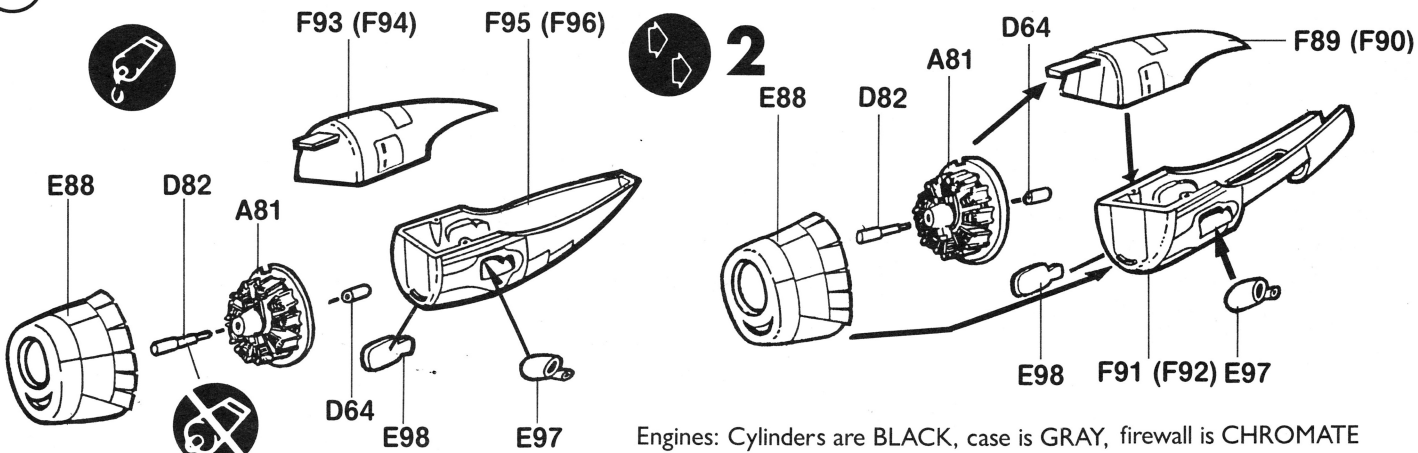

Engines: Cylinders are BLACK, case is GRAY, firewall is CHROMATE GREEN FS3515 and the superchargers are weathered RUST.

9

CLEAR GREEN

I147

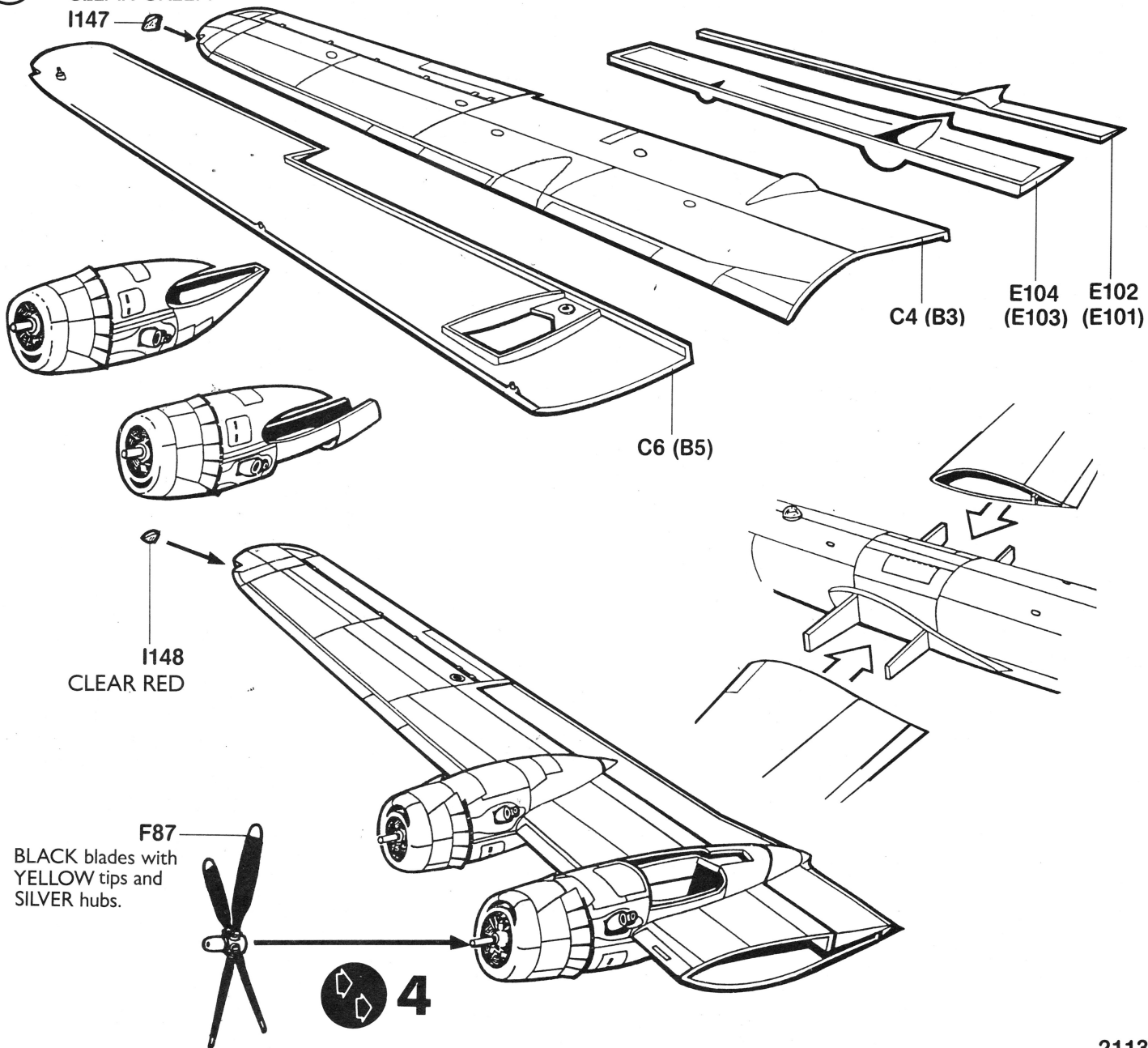

10

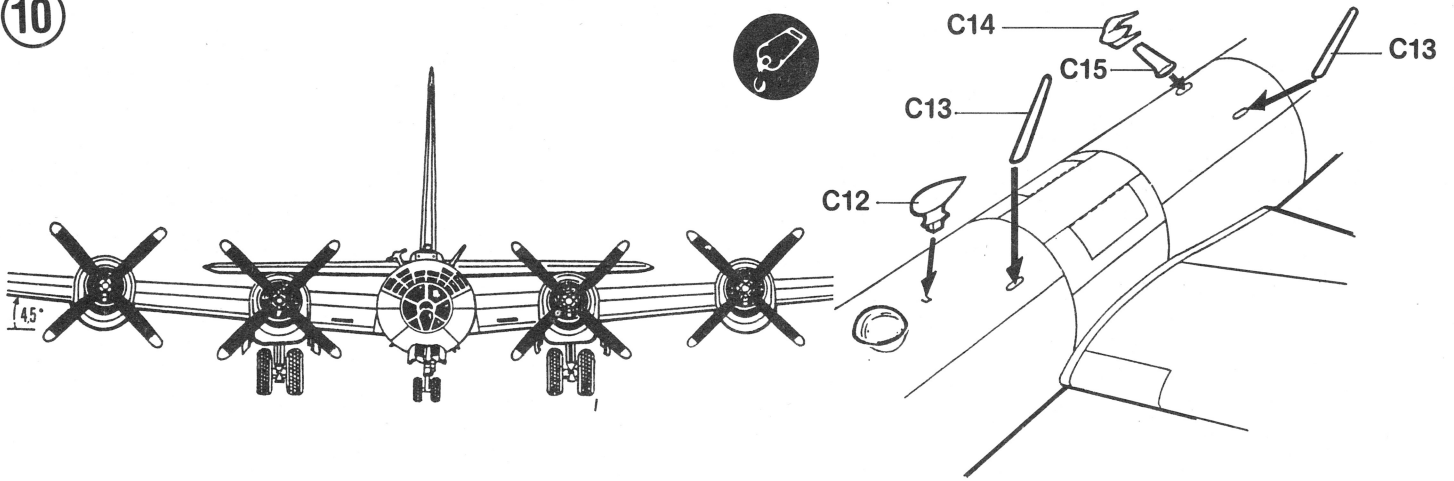

11

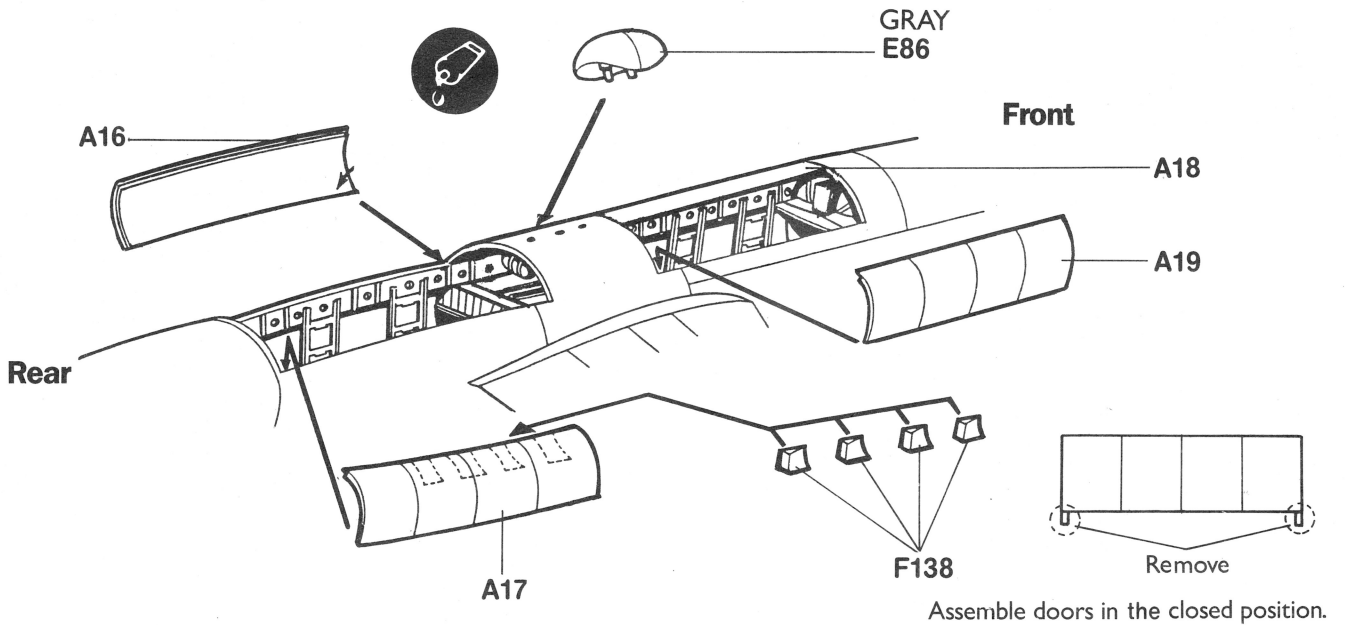

12

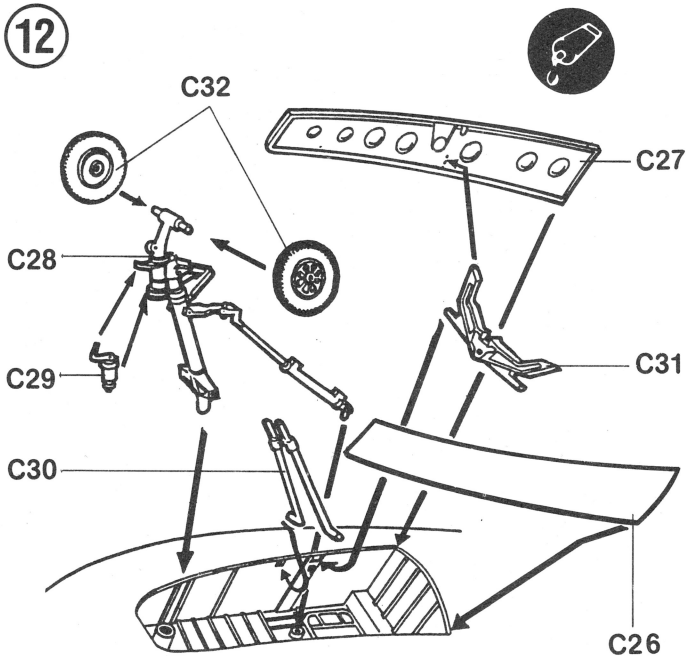

SILVER struts, wheels and inside doors and wheel wells.  
Tires are BLACK.

13

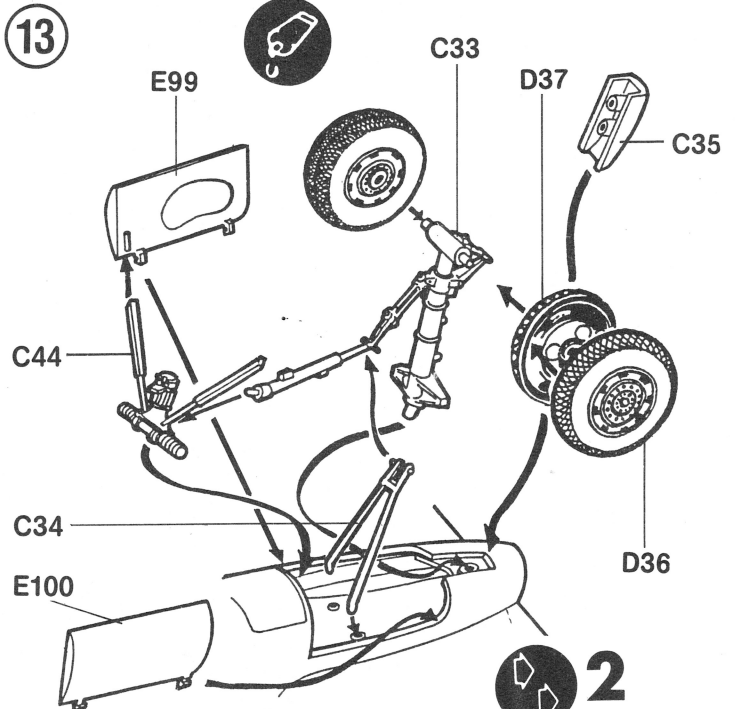

Opposite landing gear section numbers are same.

2

2113

# Painting and Decal Placement

ENGLISH	FRENCH	GERMAN	SPANISH	ITALIAN
BLACK	NOIR	SCHWARZ	NEGRO	NERO
SILVER	ARGENT	SILBERN	PLATA	ARGENTO
GUNMETAL	METALLIC	METALLIC	METALICO	METALLICO
ALUMINUM	ALUMINUM	ALUMINUMFARBEN	ALUMINIO	ALUMINIO
GRAY	GRIS	GRAU	GRIS	GRIGIO
WHITE	BLANCO	WEISS	BLANC	BLANCO
RED	ROUGE	ROT	ROJO	ROSSO
YELLOW	JAUNE	GELB	AMARILLO	GIALLO
BLUE	BLEU	BLAU	AZUL	BLU
ORANGE	ORANGE	ORANGE	NARANJADO	ARANCIO
GREEN	VERT	GRÜN	VERDE	VERDE
BROWN	BRUN	BRAUN	MARRON	MARRONE
GOLD	DORE	GOLD	DORADO	ORO
GLOSS	LUSTRE	GLANZENDES	BRILLANTE	BRILLANTE
FLAT	TERNE	GLANZLOSES	APAGADO	OPACO
CLEAR	CLAIR	KLAR	CLARO	CHIARO

Entire aircraft is SILVER metal.

© 1992 Minicraft Models Inc.

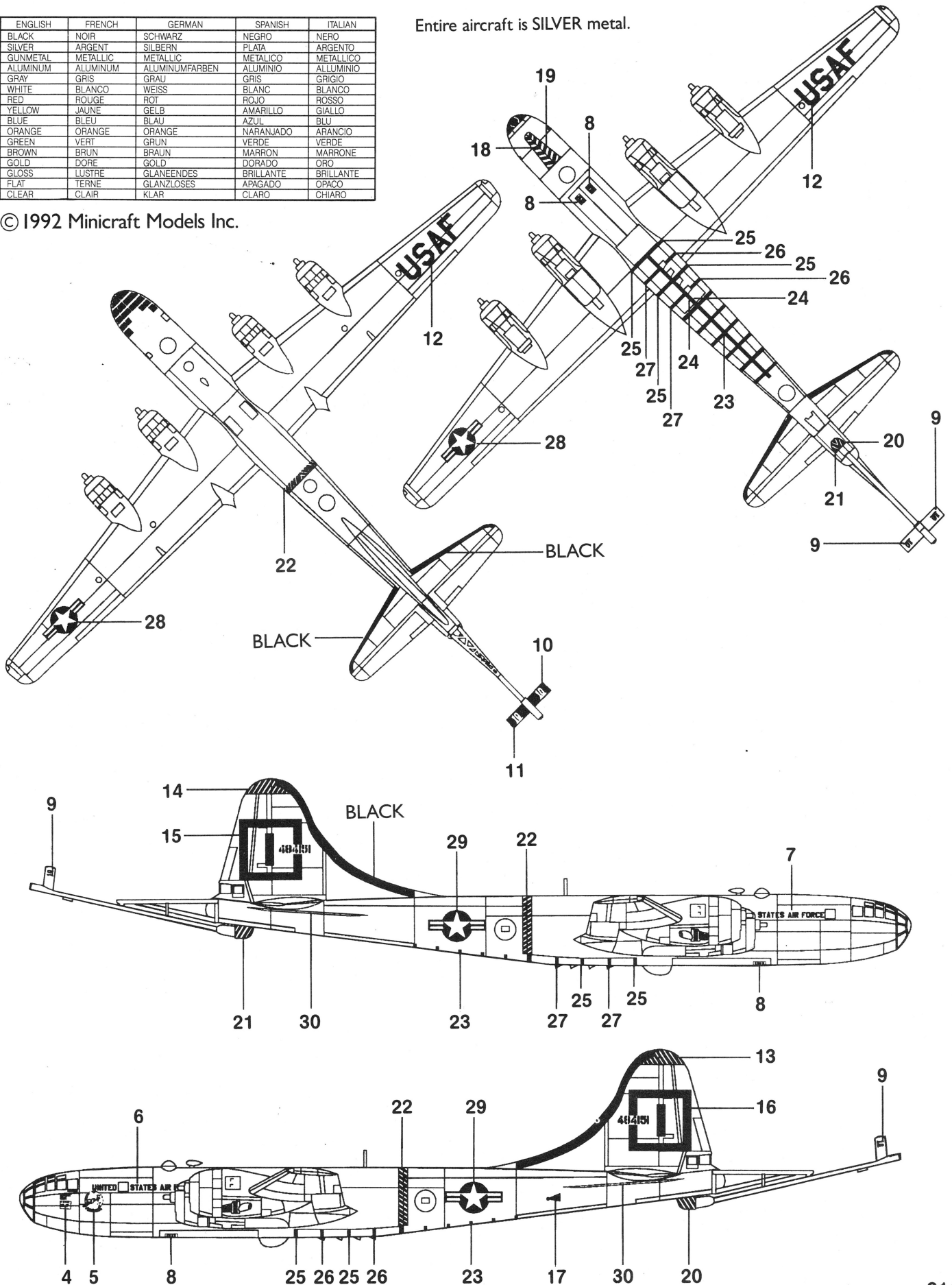

# Parts Locating Diagram.

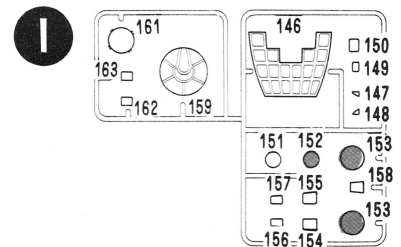
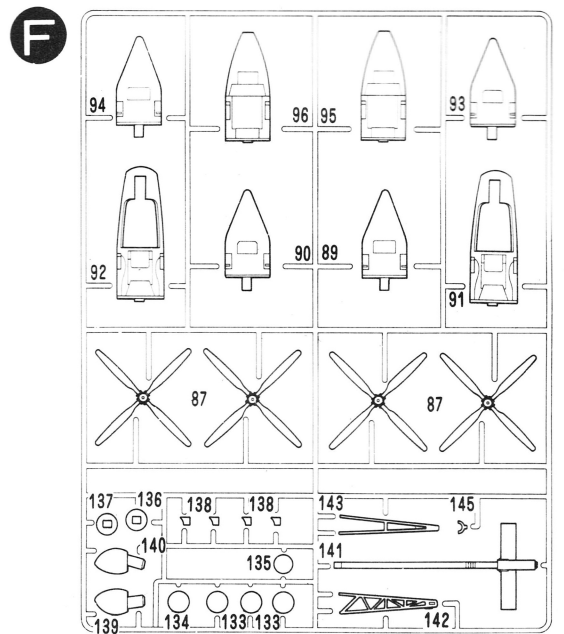
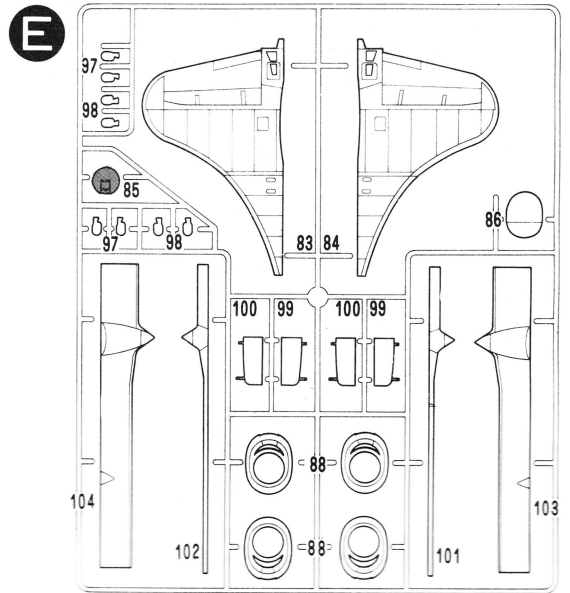
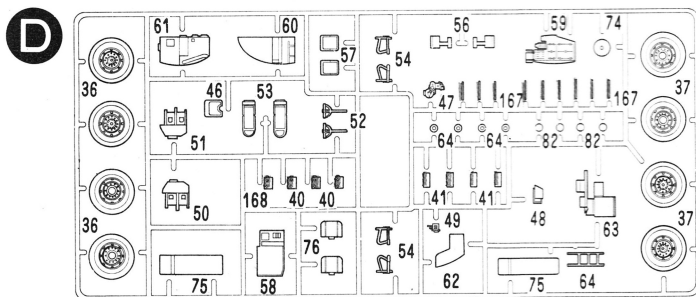
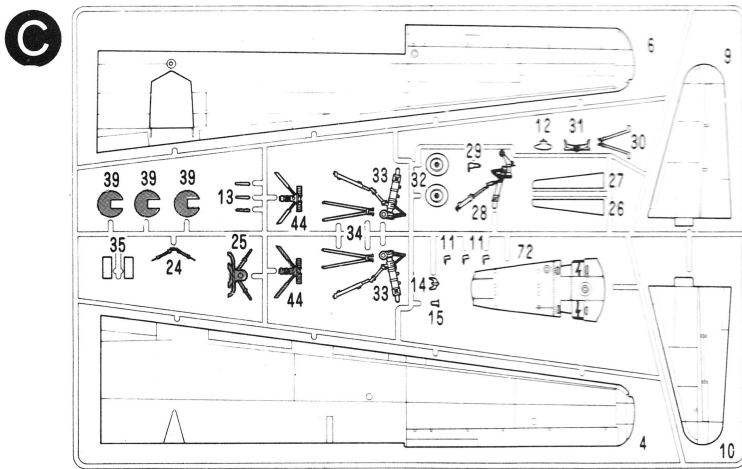
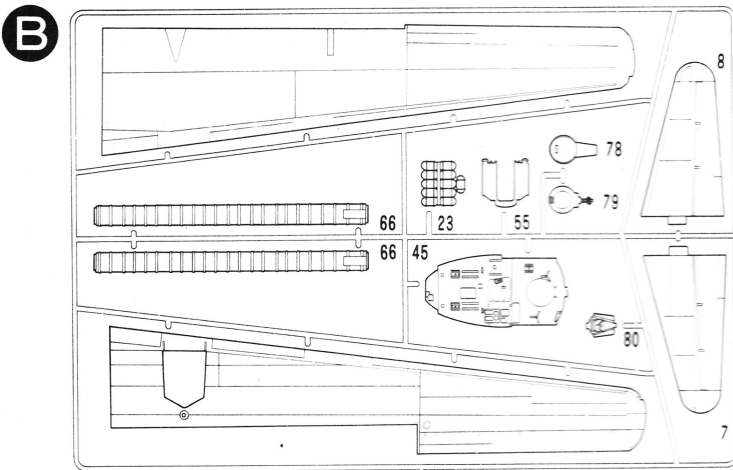
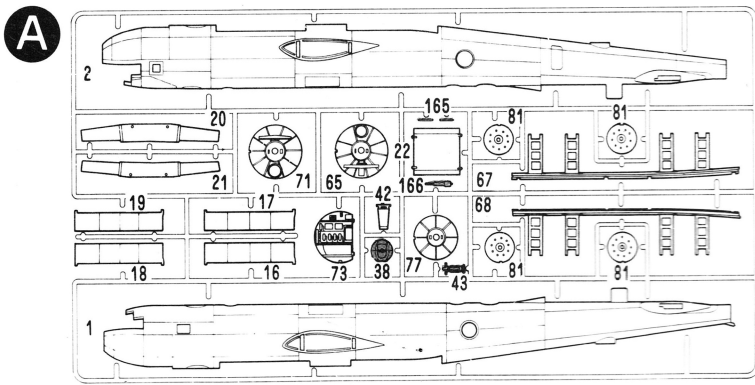

Shaded parts are not used.

Minicraft Models, Inc.  
1510 W. 228th St.  
Torrance, Calif, 90501

