



SW 72105 scale: 1/72

Shooting Star over Korea  
**Lockheed RF-80A**



The airplane had its origin in June 1943, when Lockheed was requested to design a fighter around the De Havilland turbojet engine developed in England in response to Germany's twin-engine jet fighter, the Messerschmitt Me 262. It was flown for the first time on January 8, 1944, and its performance was very good. The USAAF planned to build the Shooting Star in large numbers. However, only few of the machines arrived in Italy before the end of the war in Europe, and these were never used in operations. Anyway production continued, but in smaller scale.

In 1947 P-80 changed its name to F-80, because newly independent USAF redesignated F (as fighter) to P (as pursuit).

Lockheed built 917 F-80A's and B's, one of which was modified for an attempt on the world speed record. On June 19, 1947, this plane achieved a speed of 623.8 miles per hour. Some of these modifications were retained in the F-80C, 798 of which were produced in 1948 and 1949. F-80C had an ejection seat and explosive canopy ejection system. When war started in Korea, F-80's were sent to the battle area to help the South Koreans. On November 10, 1950, Lieutenant Russell Brown, flying a Shooting Star, made history when he destroyed a Russian MiG-15 fighter in the world's first decisive all-jet combat. However during later stages of war, P-80Cs were used in ground attack role, being superseded by F-84 and F-86.

**Specification**

The Shooting Star was a single-engine single-seat turbojet fighter capable of speeds beyond 500 miles per hour. The system was armed with a standard array of 6 x 12.7mm .50 caliber machine guns. Provision for drop bombs and air-to-surface rockets would also be added to the armament capabilities.

Need of tactical fighter reconnaissance led to modification of F-80 to carry out this role. One airframe has been modified by removing the guns and using longer nose which housed a set of cameras - this was the prototype XFP-80A, followed by 38 aircraft known as FP-80A-5-LO, followed by a second batch of next 13 aircraft.

66 fighters P-80A were converted to next batch RF-80A-15-LO. RF-80A proved itself also during the Korean War flying sorties near the Yalu River as well as over North Korea and China.

**BARVA/COLOR**

**A** Černá/Black

**B** Interierová zelená/ Zelená/ Zinc chromate

**C** Stříbrná/Silver

**D** Hliník/Aluminium

**E** Světlá šedá/ Light Grey

**F** Červená/Red

**G** Žlutá/Yellow

**H** Zelená/Green

**I** Černošedá/ Tyre Black

**J** Špinavý hliník/ Dirty Aluminium

**K** Chromová/ Chrome

**L** Hnědá/Brown

**M** Kovová/Gun metal

**URETHAN**

U1 U2 U3 U4 U5

**CLEAR**

C1 C2 C3 C4 C5 C6 C7 C8 C9

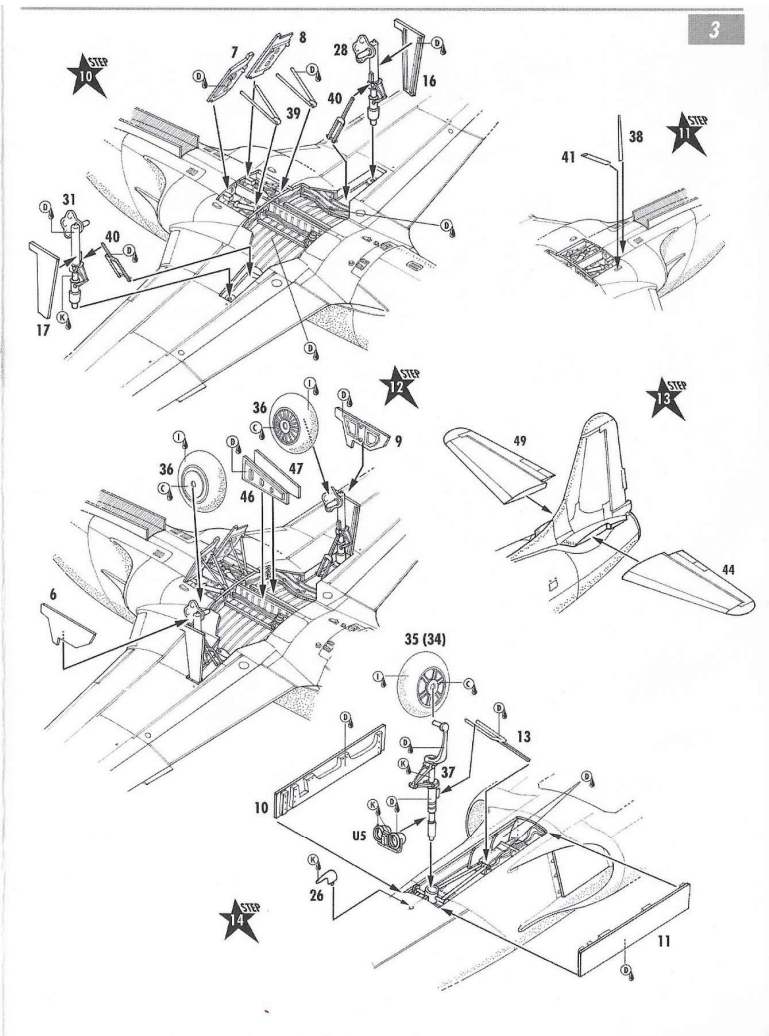
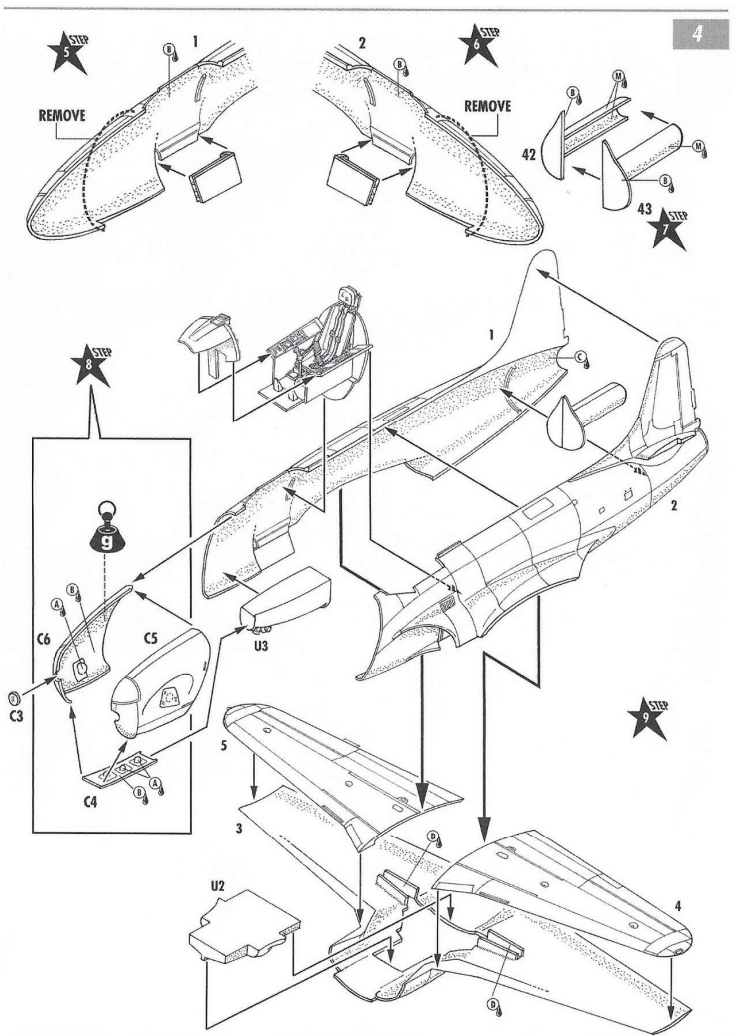

Stencil Placement and Common Data

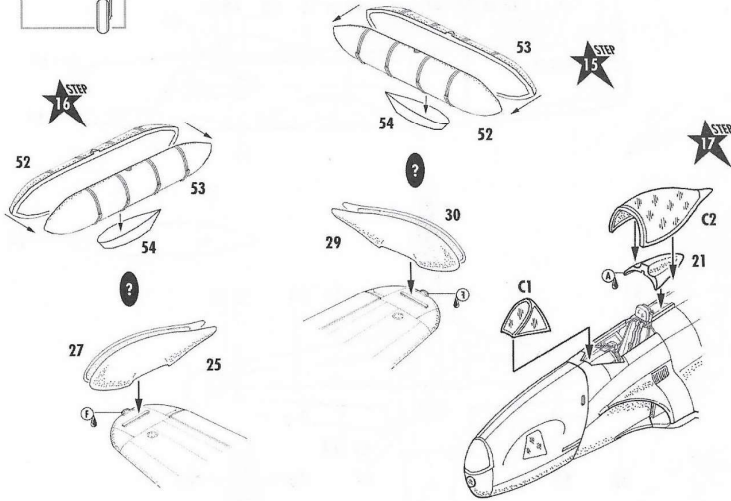
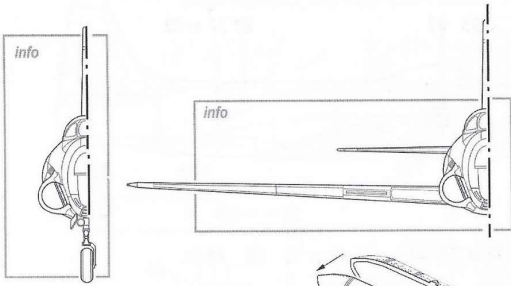
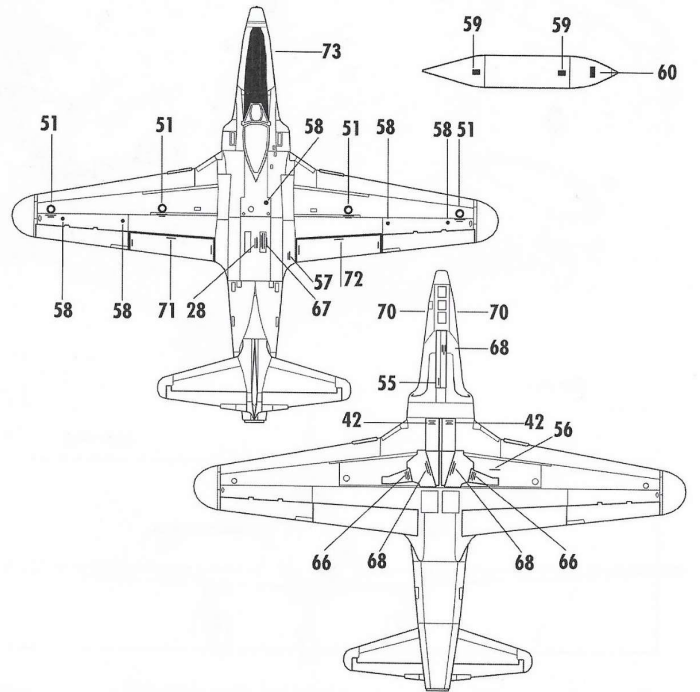
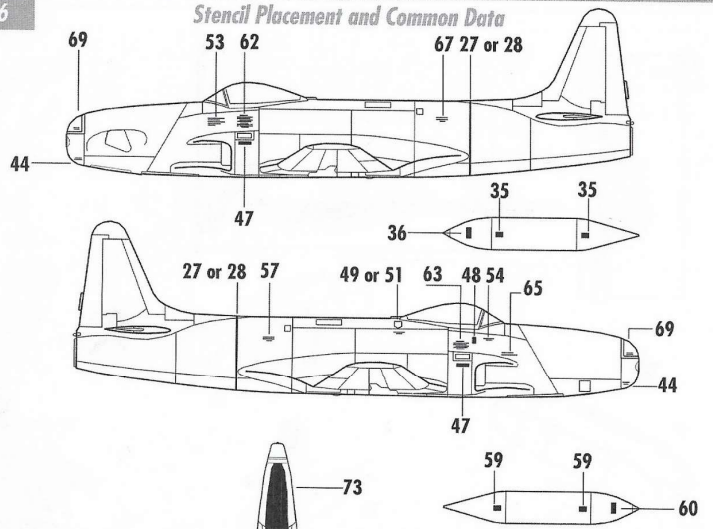

(left wing)

(right wing)

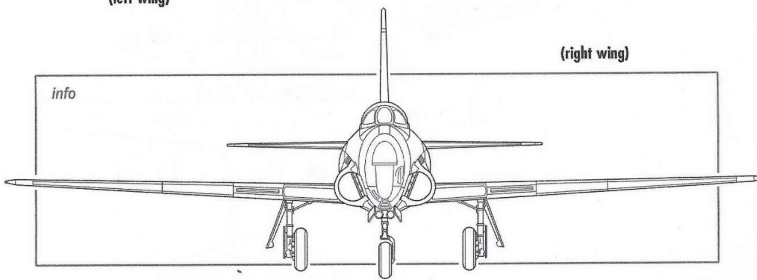

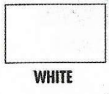
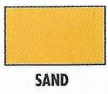
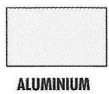
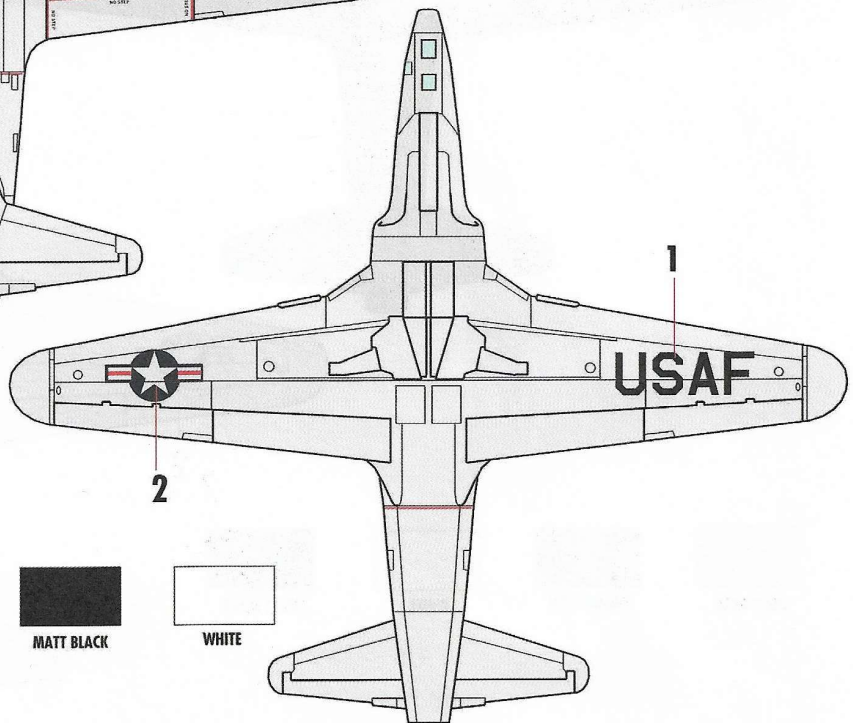
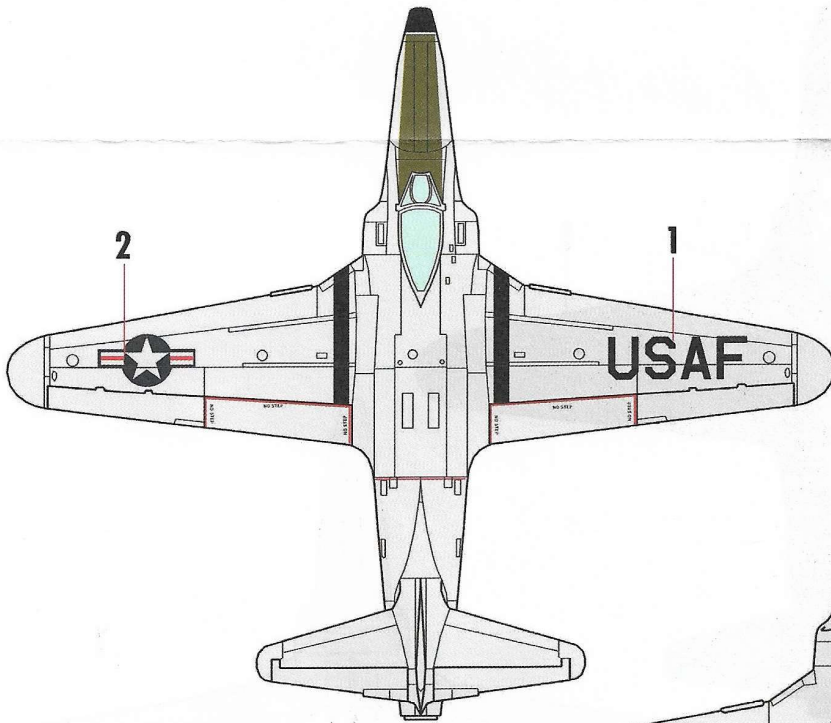
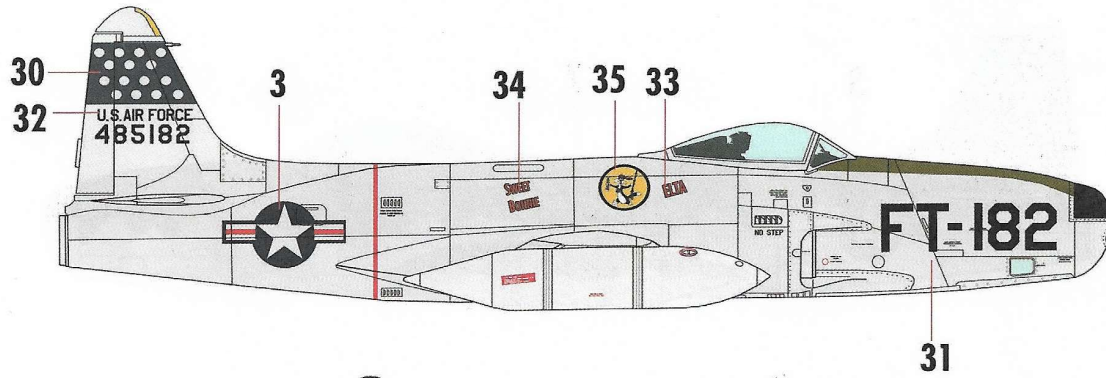
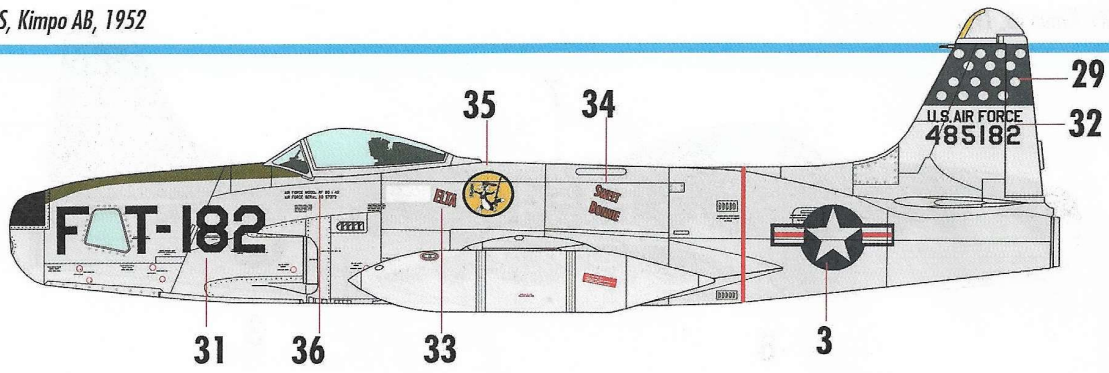

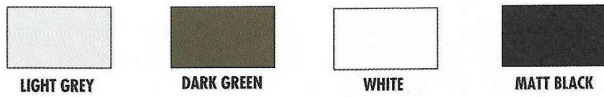
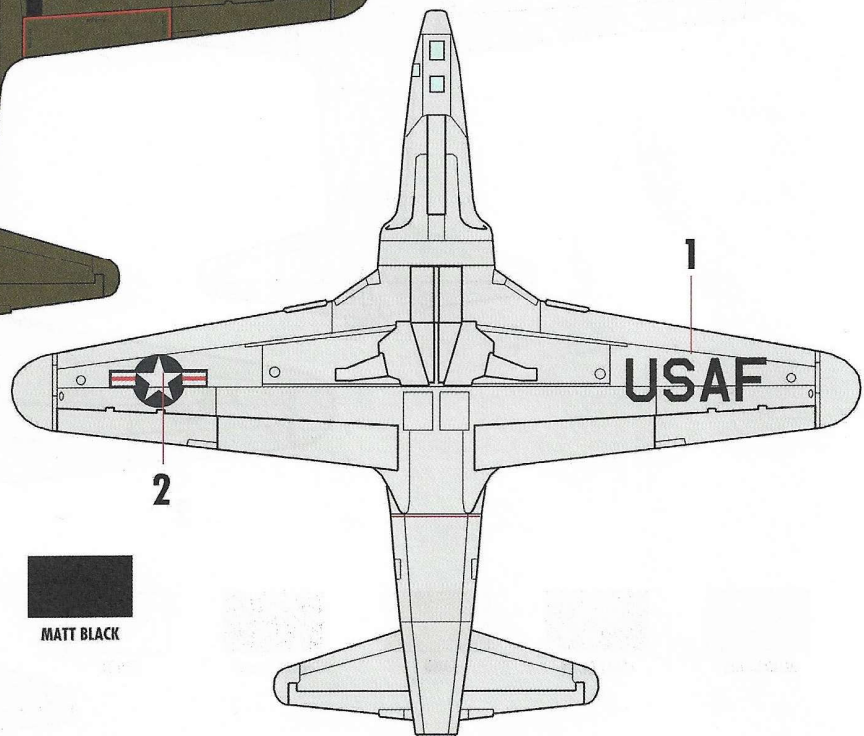
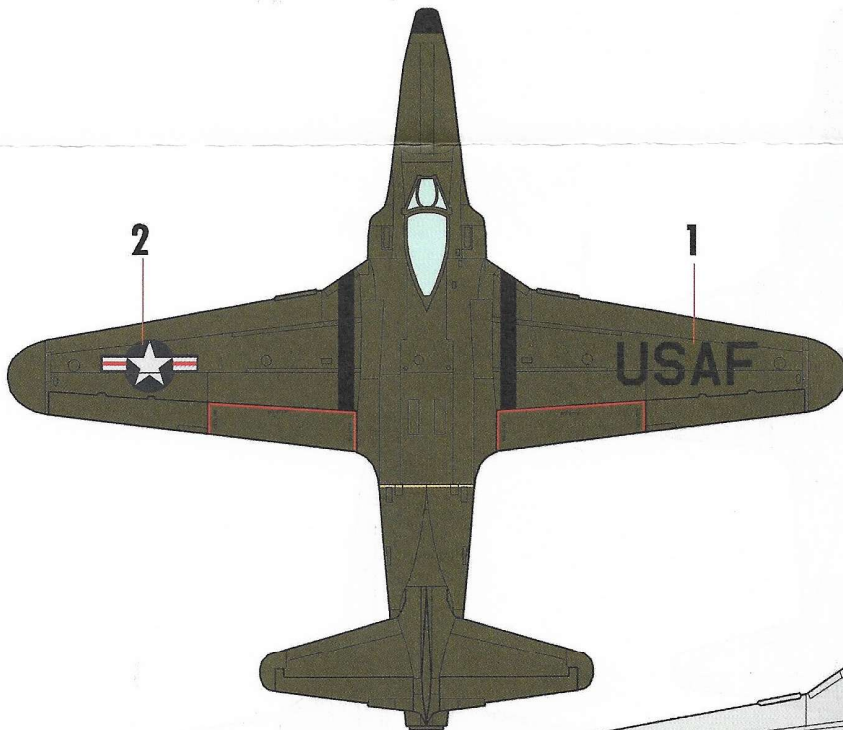
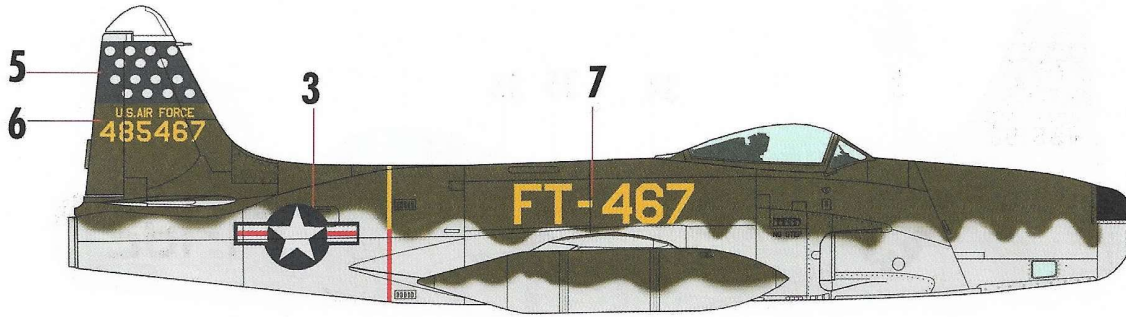
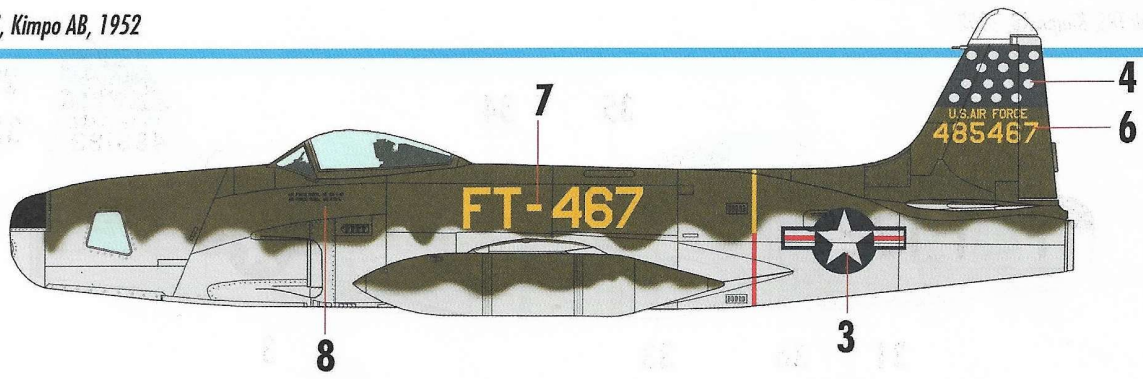

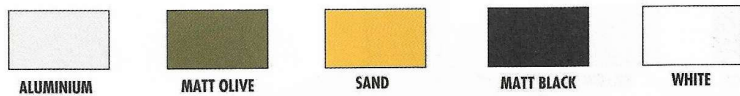
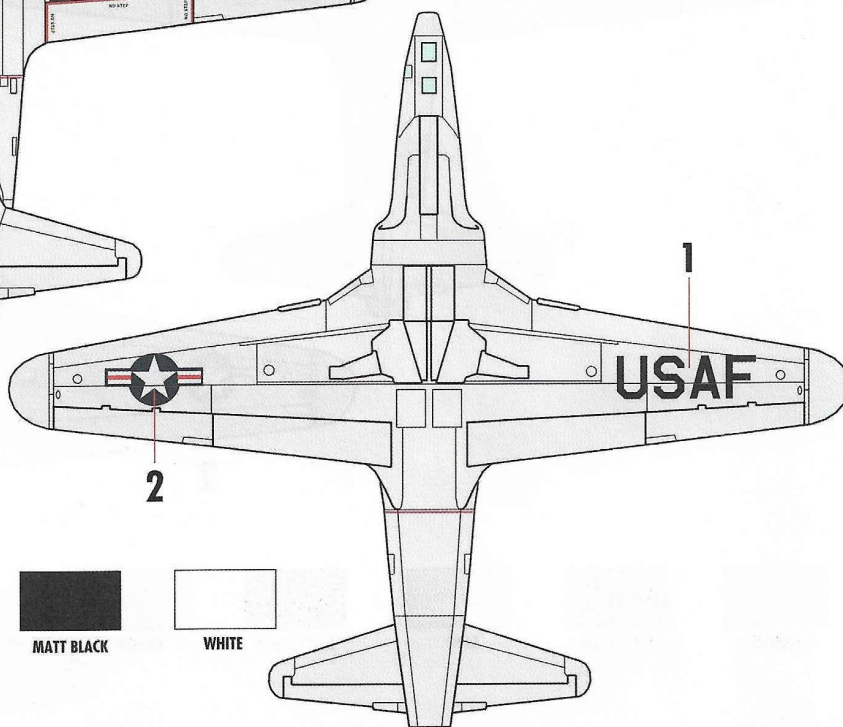
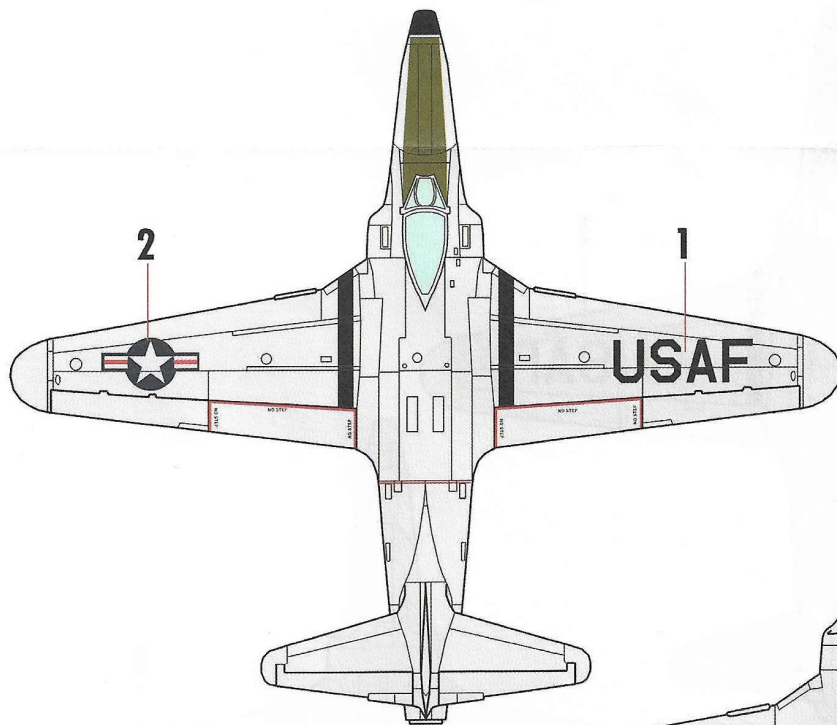
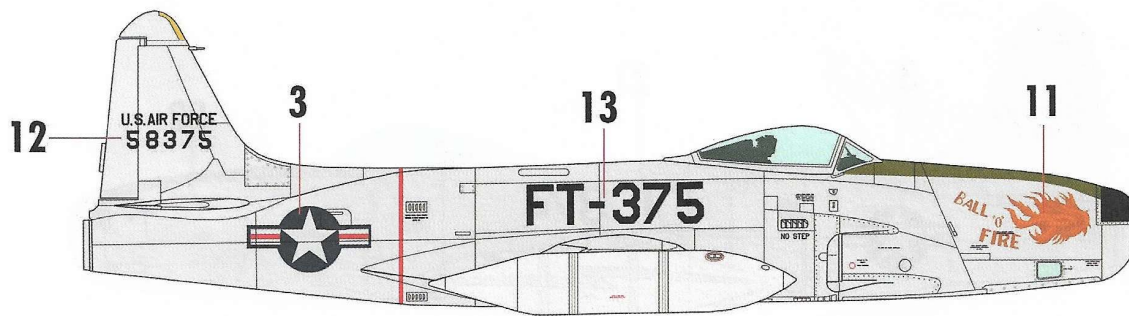
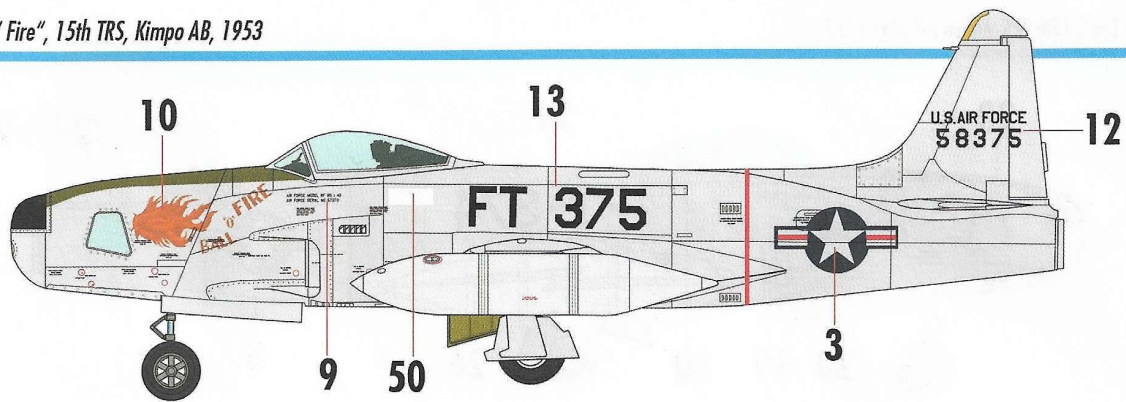

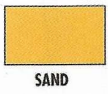
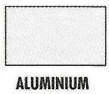
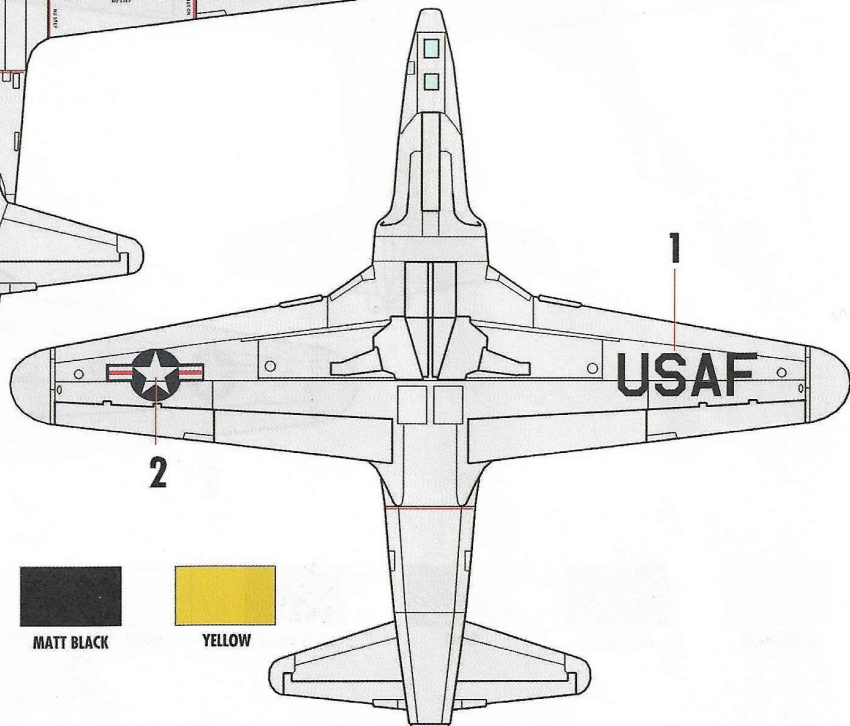
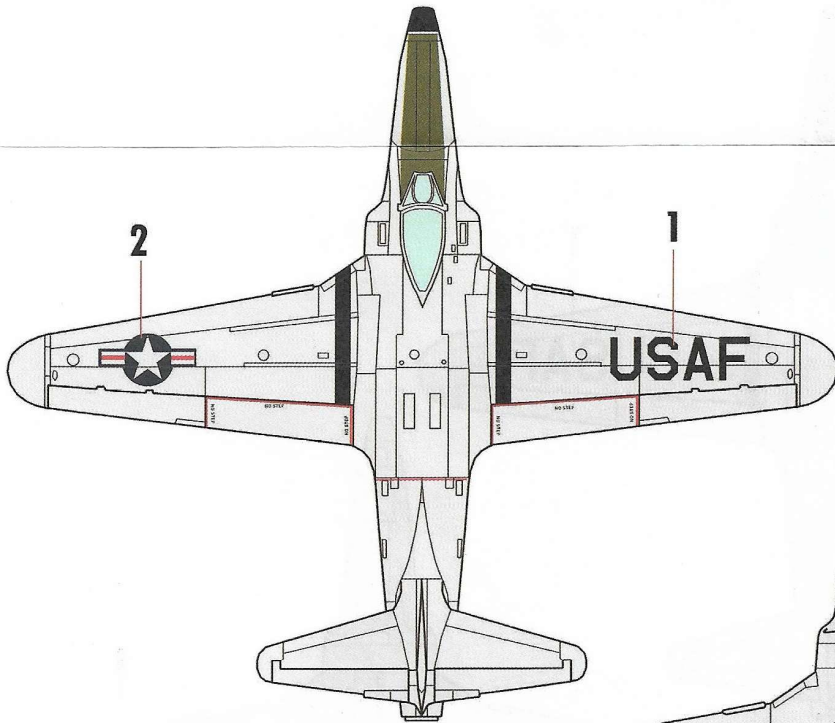
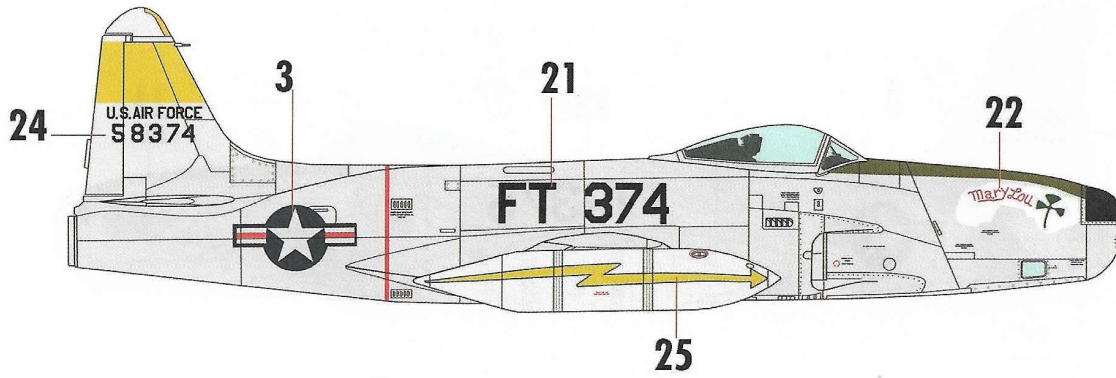
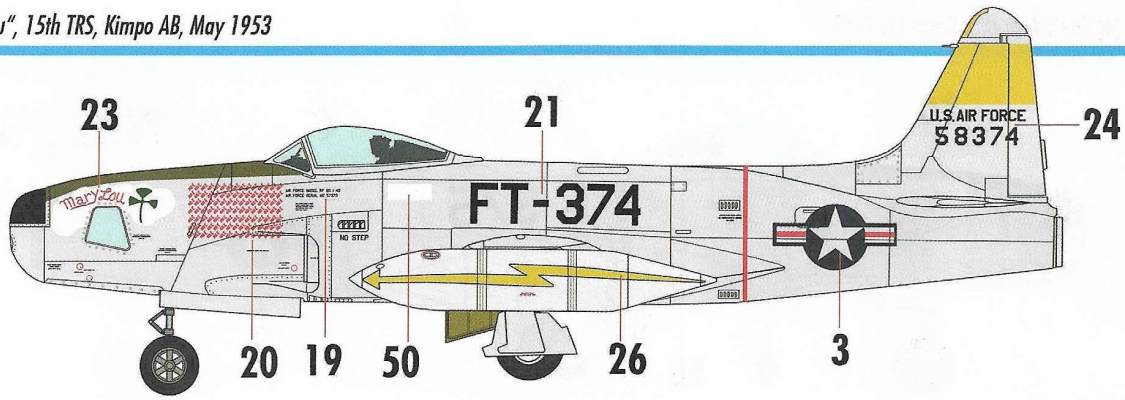

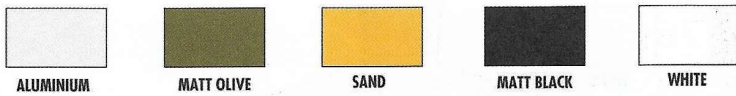
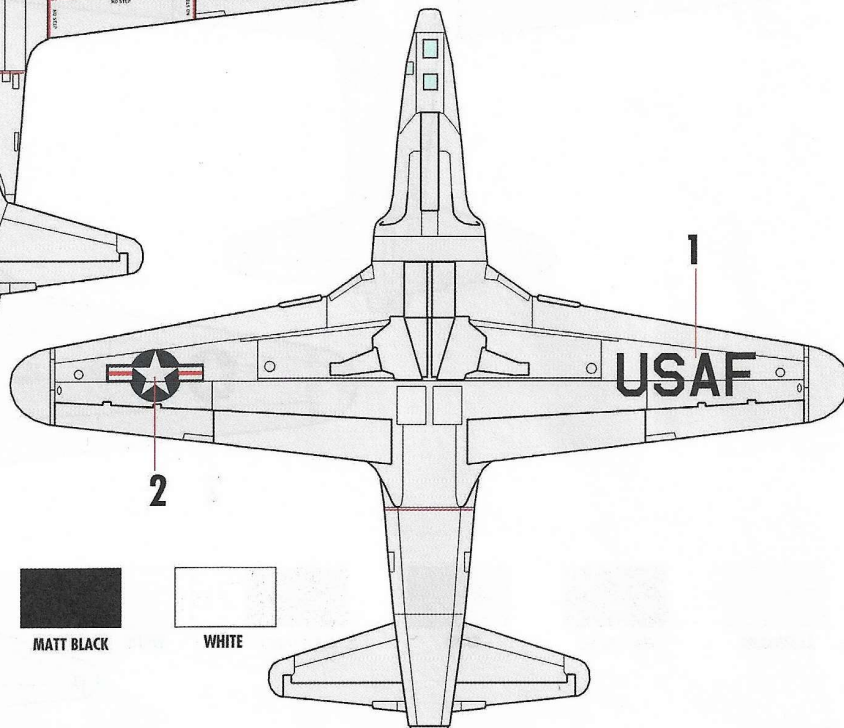
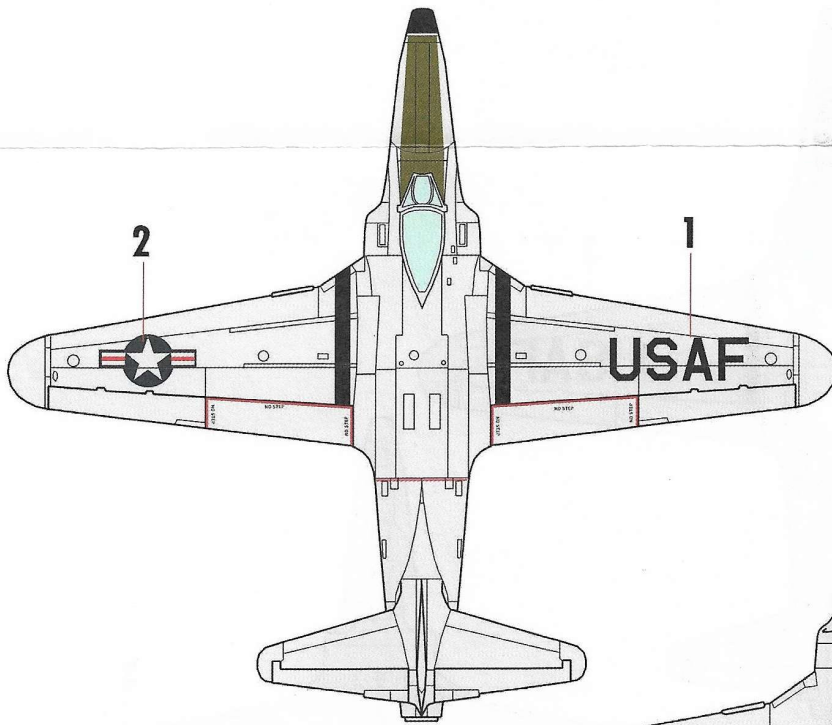
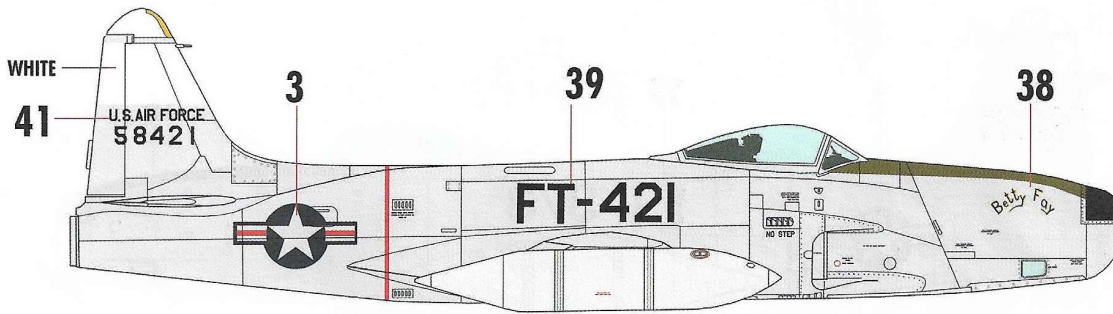
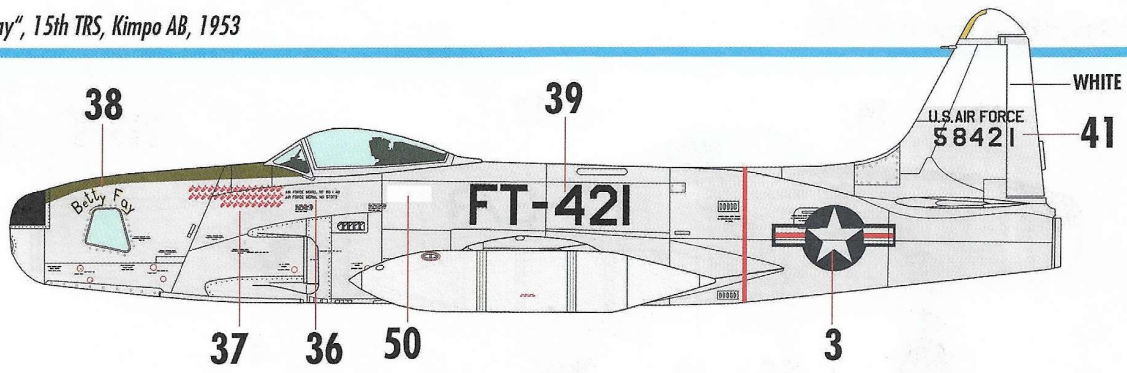



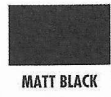
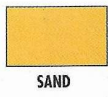
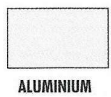
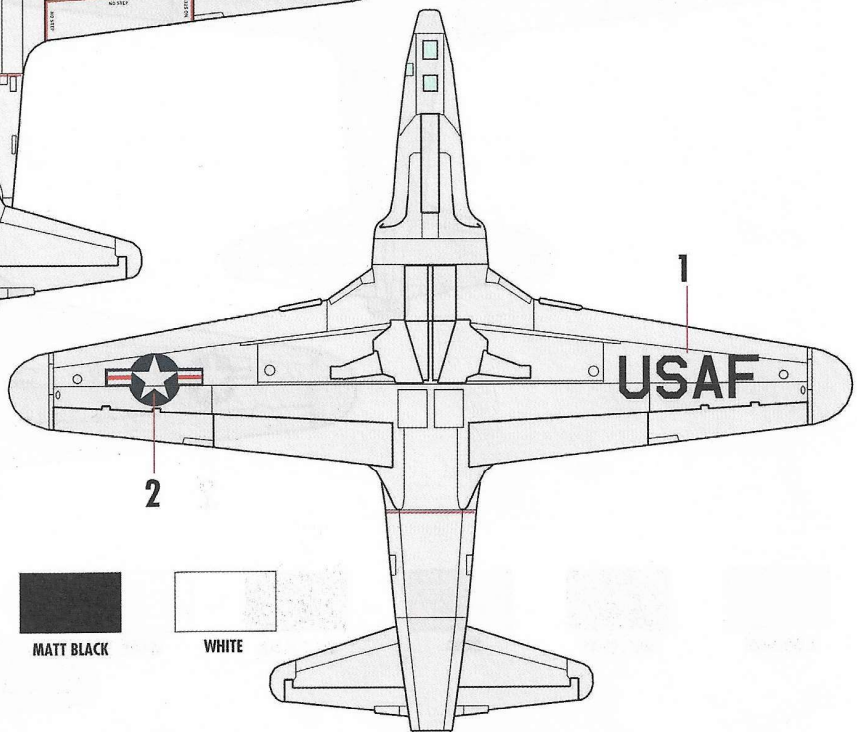
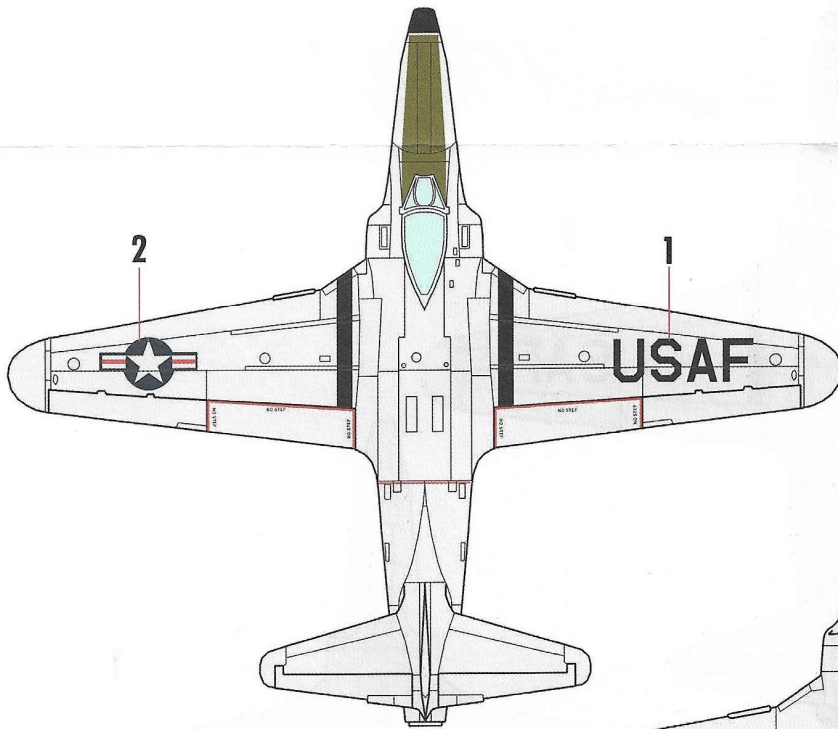
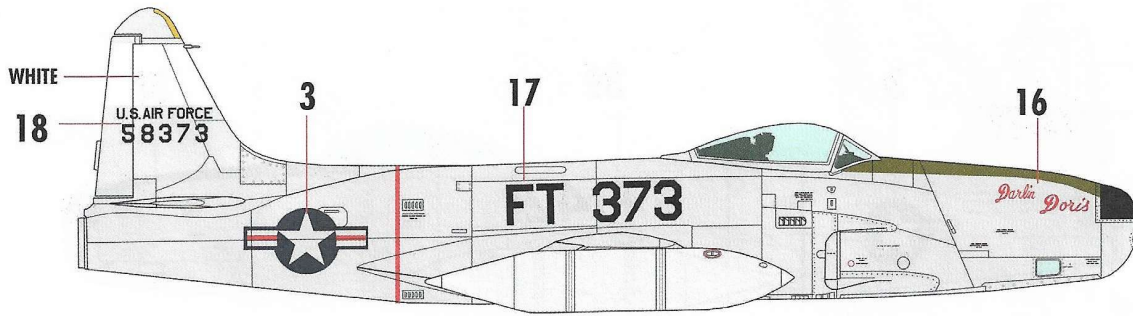
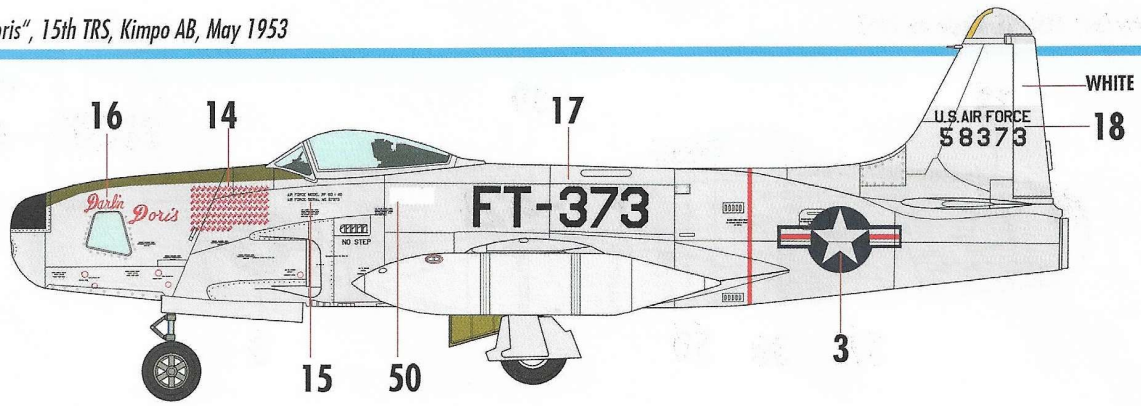

RF-80A „Darlin Doris“, 15th TRS, Kimpo AB, May 1953

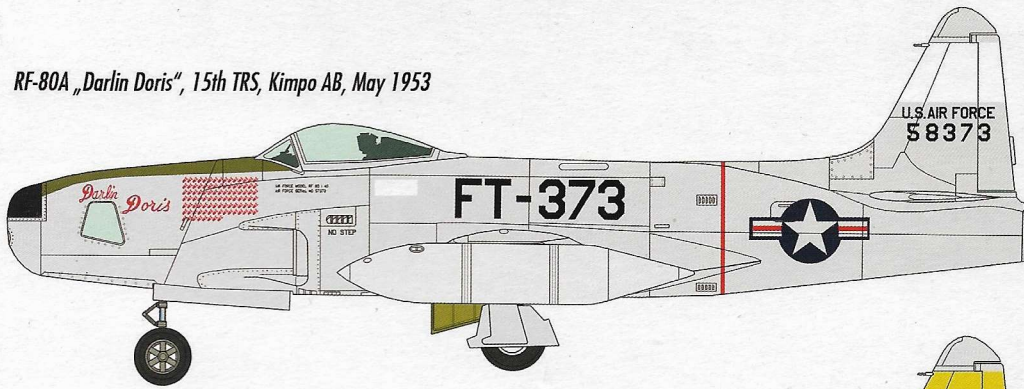

RF-80A „Mary Lou“, 15th TRS, Kimpo AB, May 1953

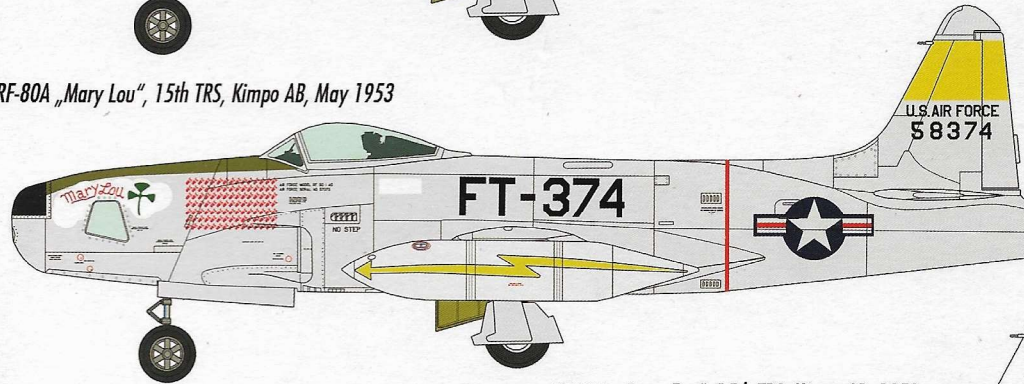

RF-80A „Betty Fay“, 15th TRS, Kimpo AB, 1953

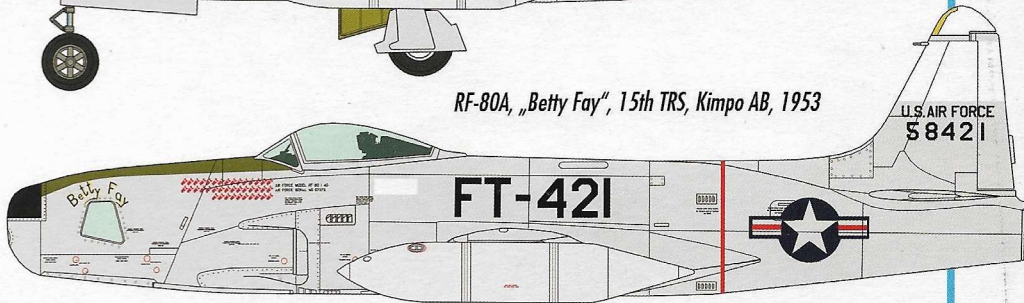

RF-80A „Ball “o” Fire“, 15th TRS, Kimpo AB, 1953



FP-80A, 45th TRS, Kimpo AB, 1952

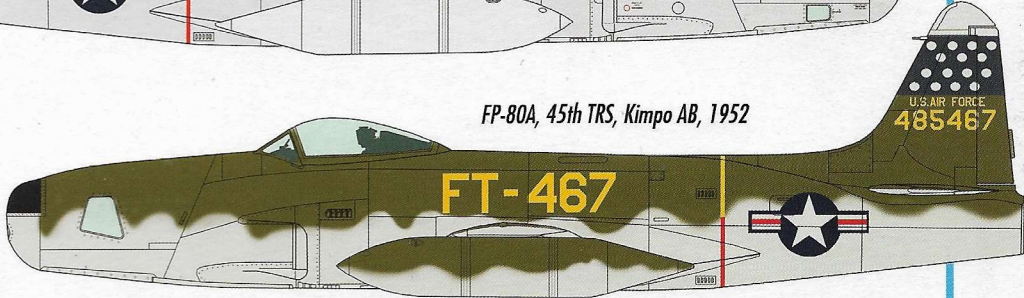

FP-80A, 45th TRS, Kimpo AB, 1952

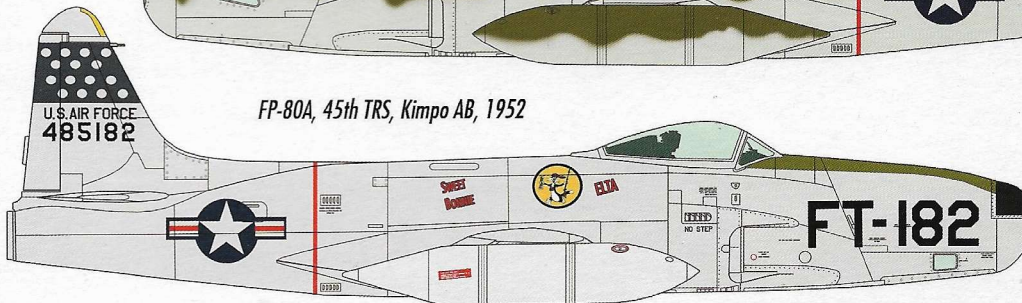

# USAF



# USAF



U.S. AIR FORCE  
485467



FT-375



*Darla Doris*

FT-373

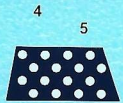

FT-467



FT-375



*Darla Doris*

FT-373



FT-467

U.S. AIR FORCE  
58375

FT-374



U.S. AIR FORCE  
58373

U.S. AIR FORCE  
58373



FT-182

U.S. AIR FORCE  
58375

FT-374



U.S. AIR FORCE  
58374

U.S. AIR FORCE  
58374



FT-182

U.S. AIR FORCE  
485182

ELTA

SWEET BONNIE



FT-182

U.S. AIR FORCE  
4 85182

ELTA

SWEET BONNIE

FT-42I

U.S. AIR FORCE  
5842I



FT-182

U.S. AIR FORCE  
4 85182

ELTA

SWEET BONNIE

FT-42I

U.S. AIR FORCE  
5842I



FT-182

U.S. AIR FORCE  
4 85182

ELTA

SWEET BONNIE

FT-42I

U.S. AIR FORCE  
5842I



FT-182

U.S. AIR FORCE  
4 85182

ELTA

SWEET BONNIE

FT-42I

U.S. AIR FORCE  
5842I

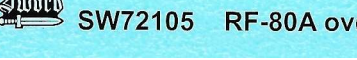

FT-182

U.S. AIR FORCE  
4 85182

ELTA

SWEET BONNIE

FT-42I

U.S. AIR FORCE  
5842I



SW72105 RF-80A over Korea

Printed by Techmod