

ISRAEL

IAI KFIR C2/C7



1/72

UNASSEMBLED MODEL KIT

INSTRUCTIONS



AMK
AvantGarde Model Kits

86002 IAI KFIR C2/C7 (86B002-09)

ISRAEL IAI KFIR C2/C7

幼獅戰鬥機

以色列飛機工業公司“幼獅”Kfir (希伯來語：קפיר) 是以色列製造的全天候多用途作戰飛機，改良自法國達索公司幻影5的機身基礎上，“幼獅”加裝了以色列的航空電子設備和以色列的國產版通用電氣J79渦扇噴射發動機。

“幼獅”於1975年開始服役於以色列空軍，第一台被分配到第101“第一戰士”中隊。在隨後的幾年中，其他幾個中隊都配備了新的飛機。於1976年第一架F-15鷹式戰鬥機從美國交付到以色列後，“幼獅”作為以色列空軍主要空中優勢戰鬥機的短暫任務週期就結束了。

1977年11月9日，以色列空襲一個黎巴嫩游擊隊訓練營。是“幼獅”的第一個有記錄的作戰行動，“幼獅”戰鬥機的唯一空戰勝利在1979年6月27日發生，編號874的以色列空軍“幼獅”C2擊落了一架敘利亞軍米格-21戰鬥機。

1982年以色列與黎巴嫩戰爭(加利利和平行動)的時候，以色列空軍的F-15和F-16戰鬥機發揮了強大的空中優勢的作用，讓“幼獅”可在沒有護航的情況下進行對地打擊空襲任務。不久之後，所有以色列空軍“幼獅”C2開始升級到C7版本，增強了負重能力和對地攻擊功能，使得“幼獅”更適合執行戰鬥/轟炸的作戰任務。在20世紀90年代後半期，經過近20年的作戰生涯，“幼獅”戰鬥機從以色列空軍退役。

The Israel Aircraft Industries Kfir (Hebrew: קפיר "Lion Cub") is an Israeli-built all-weather, multirole combat aircraft based on a modified Dassault Mirage 5 airframe, with Israeli avionics and an Israeli-made version of the General Electric J79 turbojet engine.

The Kfir entered service with the IAF in 1975, the first units being assigned to the 101st "First Fighter" Squadron. Over the following years, several other squadrons were also equipped with the new aircraft. The role of the Kfir as the IAF's primary air superiority asset was short-lived, as the first F-15 Eagle fighters from the United States were delivered to Israel in 1976.

The Kfir's first recorded combat action took place on November 9th, 1977, during an Israeli air strike on a training camp at Tel Azia, in Lebanon. The only air victory claimed by a Kfir during its service with the IAF occurred on June 27th, 1979 when a Kfir C2 shot down a Syrian MiG-21.

During the Israeli-Lebanon war in 1982 (Operation Peace for Galilee), The IAF was able to use both its F-15s and F-16s for air superiority roles, leaving the Kfirs to carry out unescorted strike missions. Shortly afterwards, all IAF C2s began to be upgraded to the C7 version, with enhanced weight performance, making the Kfirs more suitable to its new fighter-bomber role. During the second half of the 1990s, the Kfirs were withdrawn from active duty in the IAF, after almost twenty years of continuous service.



- 產品不適合8歲以下的兒童。
- 產品中含有帶尖點的小零件。
- 對於3歲以下兒童當心因窒息產生的危害。

NOT SUITABLE FOR CHILDREN UNDER 8 YEARS.
CONTAINS FUNCTIONAL SHARP POINTS CONTAINS
SMALL PARTS. BEWARE OF CHOKING HAZARD OF
CHILDREN UNDER 3 YEARS.

PAINT AND COLOR USED

1	白色 White	
3	紅色 Red	
4	黃色 Yellow	
8	銀色 Silver	
12	橄欖色 Olive Drab	
20	淺藍色 Light Blue	
28	黑鐵色 Steel	
33	啞黑色 Flat Black	

47	透明紅 Clear Red	
50	透明藍 Clear Blue	
54	卡其綠色 Khaki Green	
61	燒鐵色 Burnt Iron	
73	飛機灰色 Aircraft Gray	
137	車胎黑 Tire Black	
307	灰色 Gray (FS 36320)	
308	淺灰色 Gray (FS 36375)	

310	棕褐色/Brown (FS 30219)	
312	綠色/Green (FS 34227)	
313	沙漢黃色/Sand Yellow (FS 33531)	
314	淺綠色/Light Green (FS 35622)	
316	白色/White (FS 17875)	

1 Cockpit 座艙

Placement of Instrument Decals

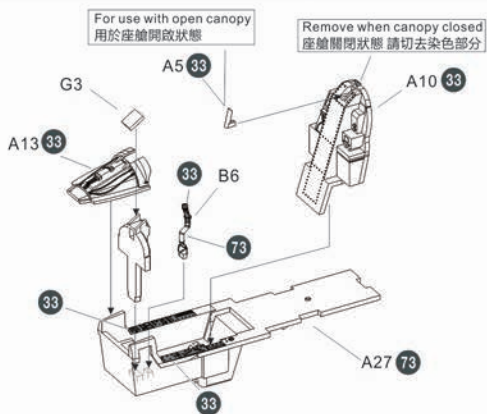
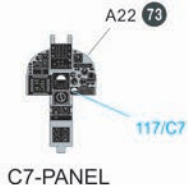
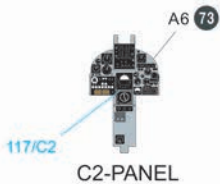

2 Front Landing Gear Bay 前起落架艙

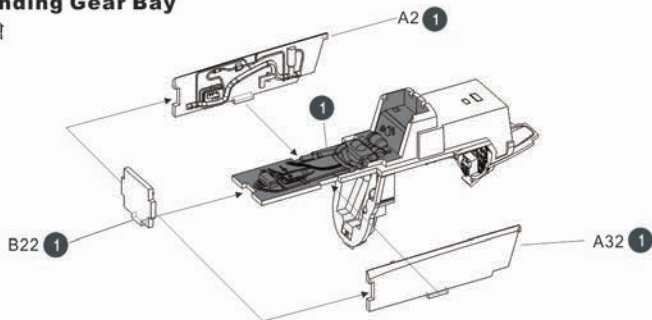

3 Attaching Fuselage 組裝機身

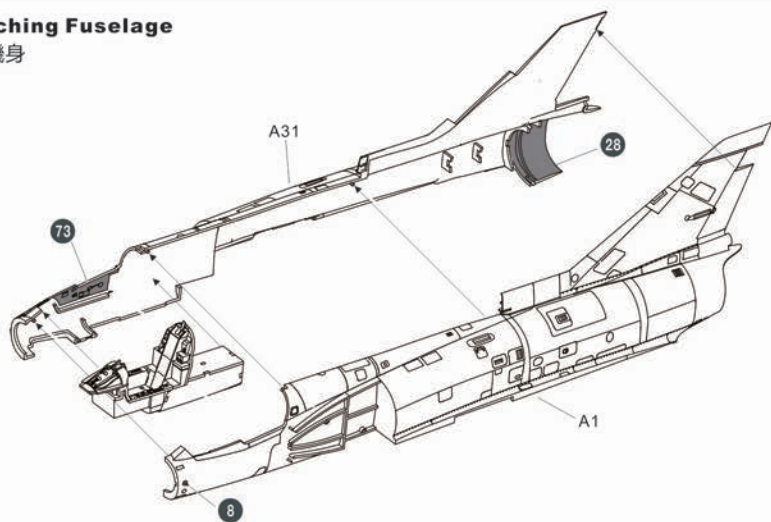

4 Attaching Main Landing Gear 安裝主起落架艙

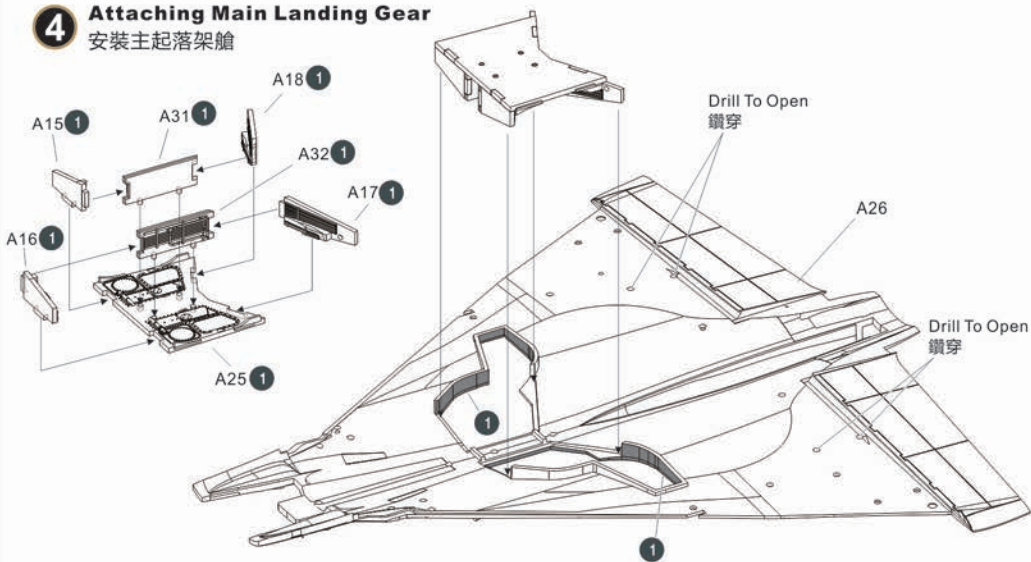

5 Attaching Main Wings 安裝主機翼

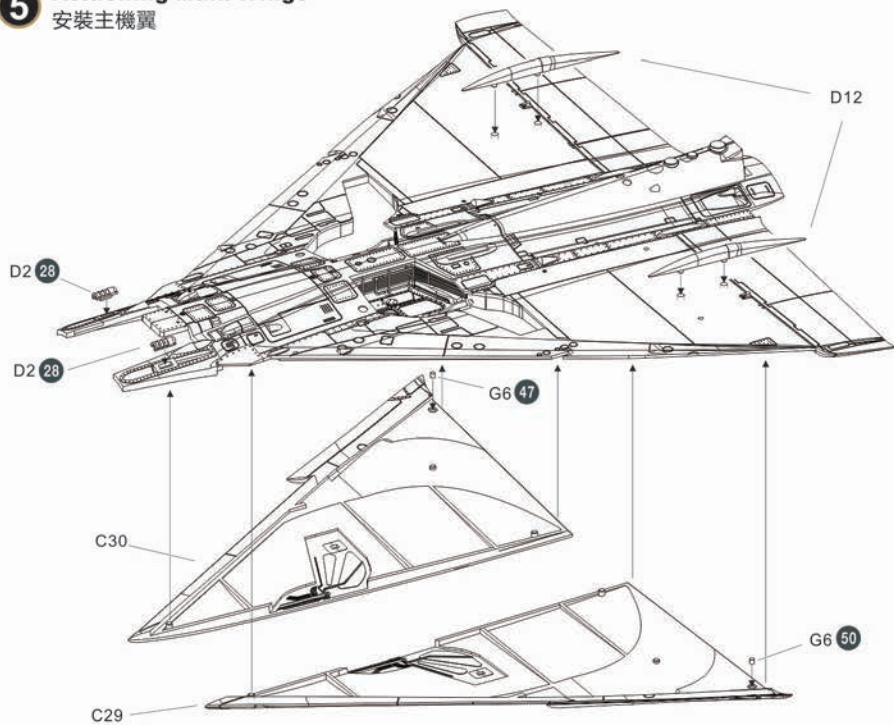

7 Top Fuselage & Main Wings
上機身及主機翼

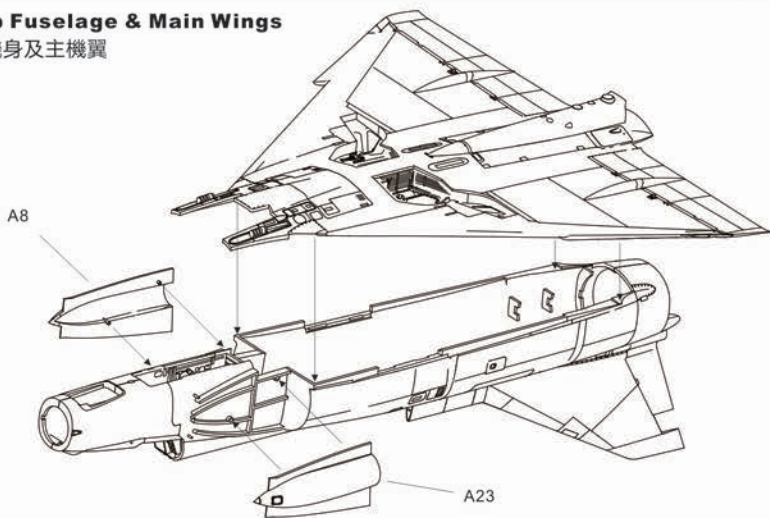

8 Attaching Air Intakes and Canards
進氣口與前翼裝配

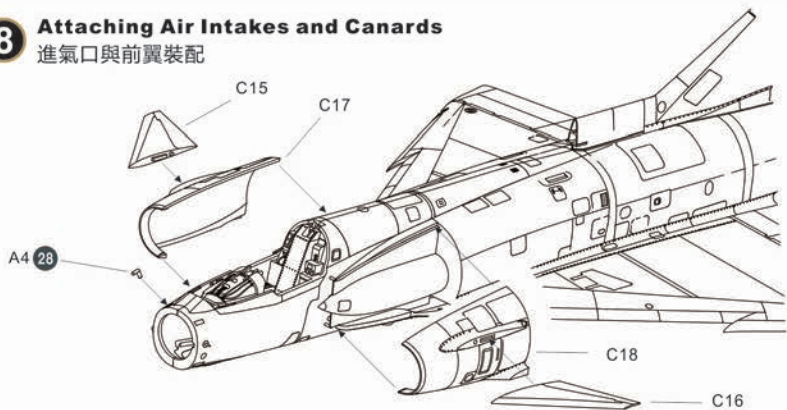

9 Attaching upper Fuselage Parts
機身上方小零件裝配

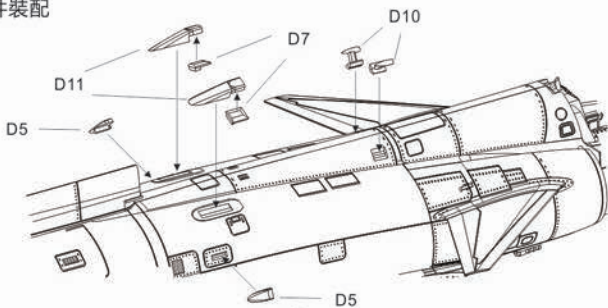

10 Attaching Main Landing Gear Doors

安裝主起落架艙門

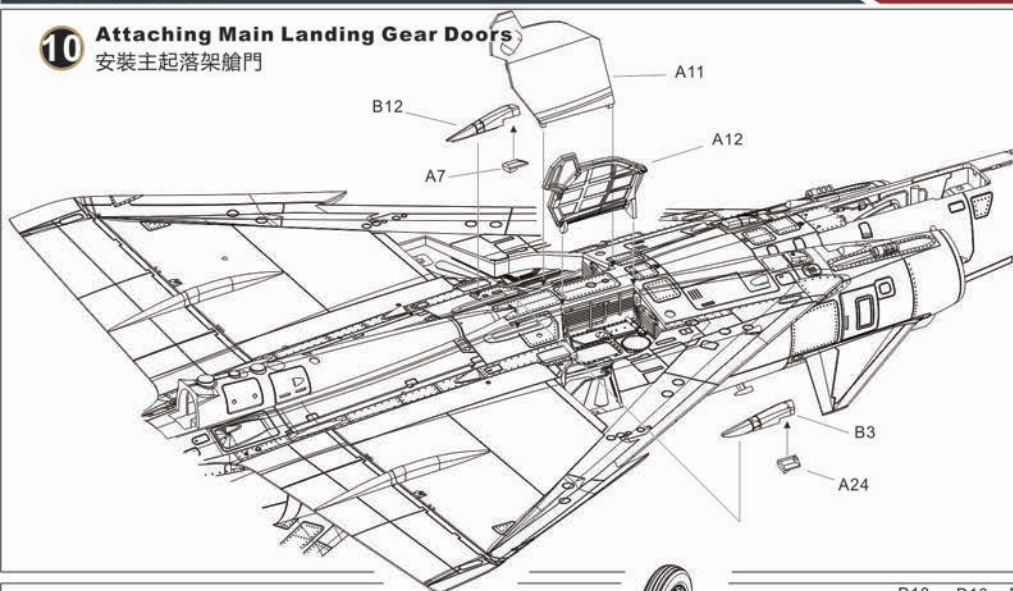

11 Attaching Main Landing Gear

安裝主起落架

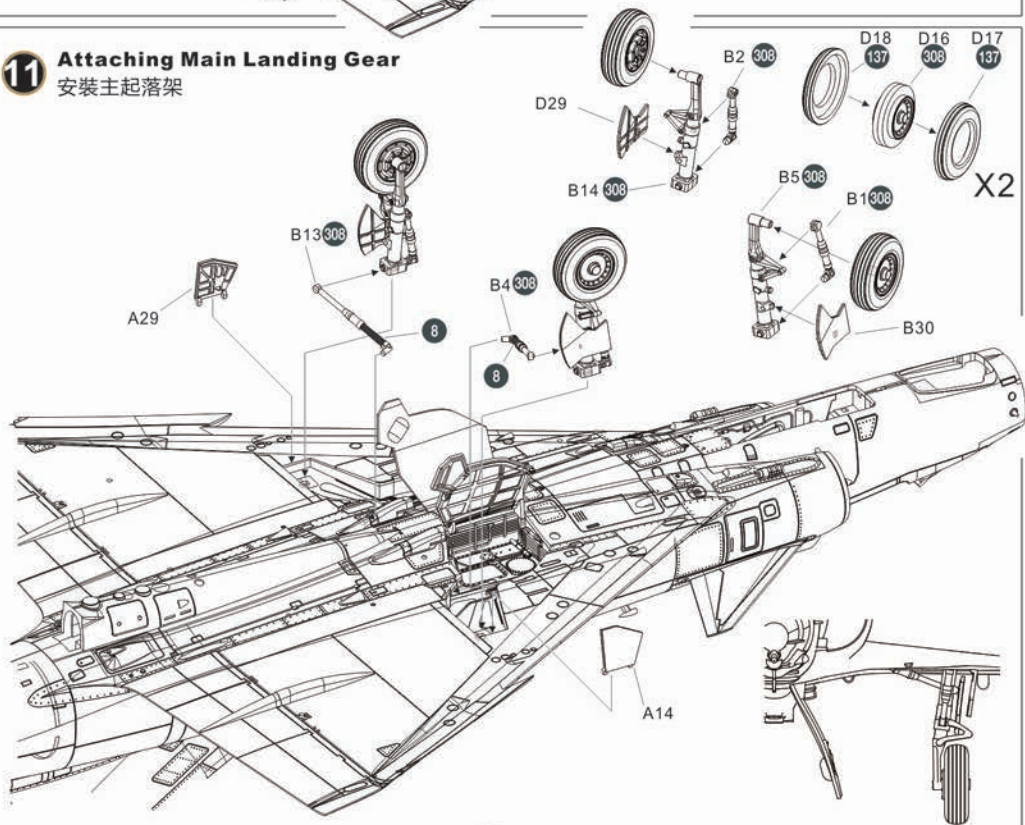

12 Attaching Nose Landing Gear

安裝前起落架

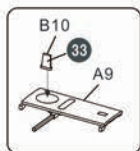

For C7 only

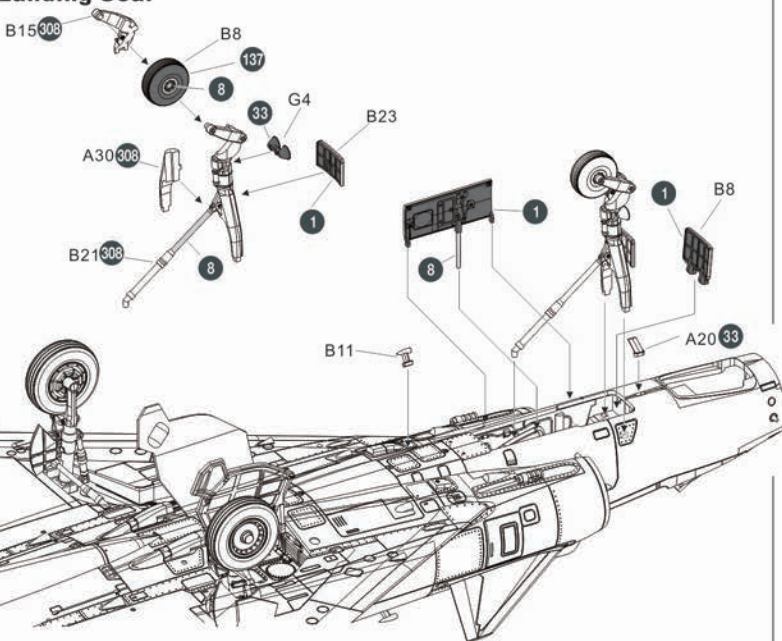

13 Attaching Nose

安裝機頭

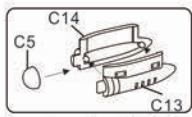

Pave penny laser designer

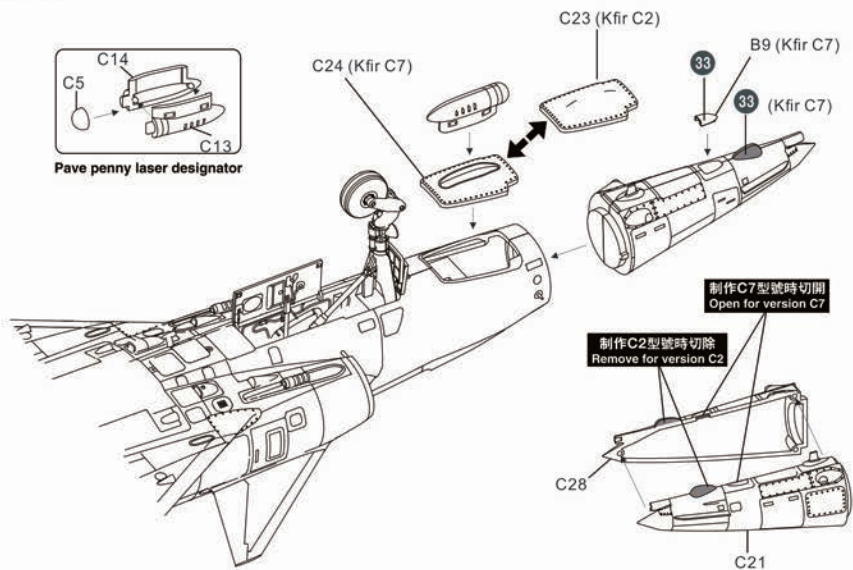

14 Nozzle
引擎噴口

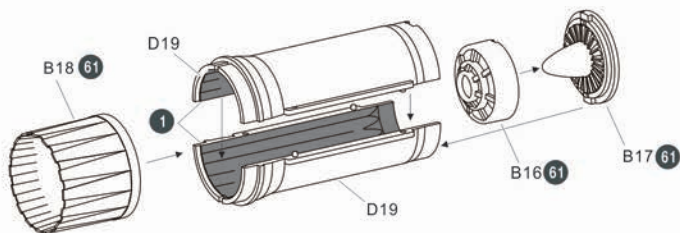

15 Attaching Nozzle
安裝引擎

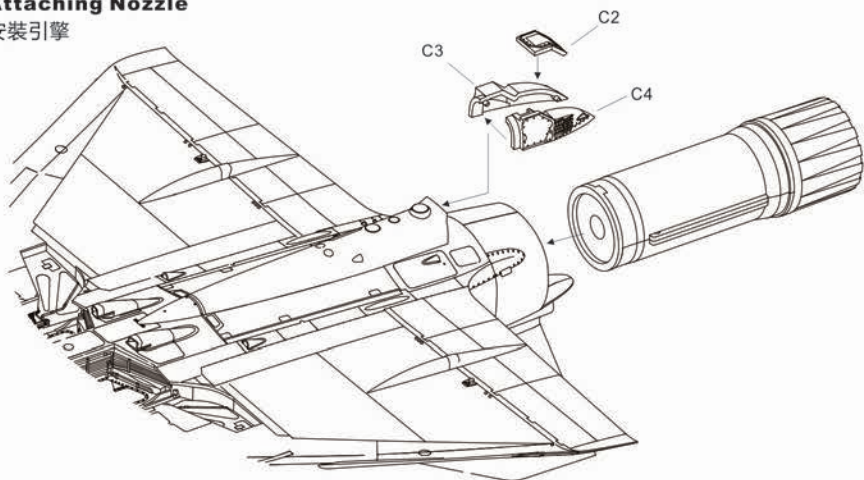

16 Other Parts
机身小配件

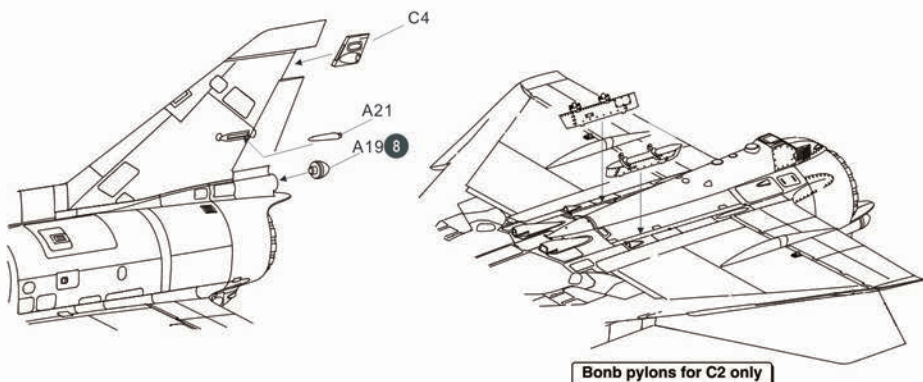

17 C2 Ejection Seat C2 型號彈射座椅安裝

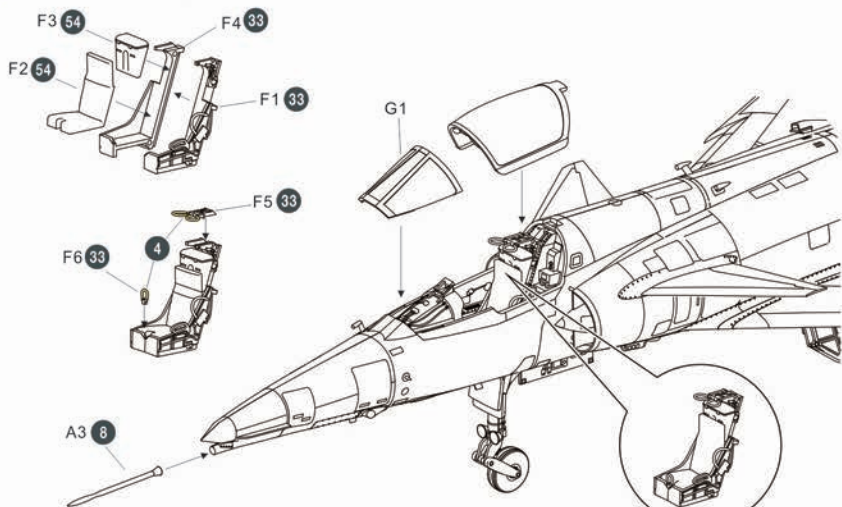

MB JM6 ejection seat

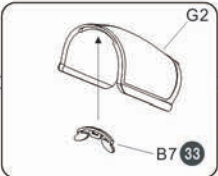

18 C7 Ejection Seat C7 型號彈射座椅安裝

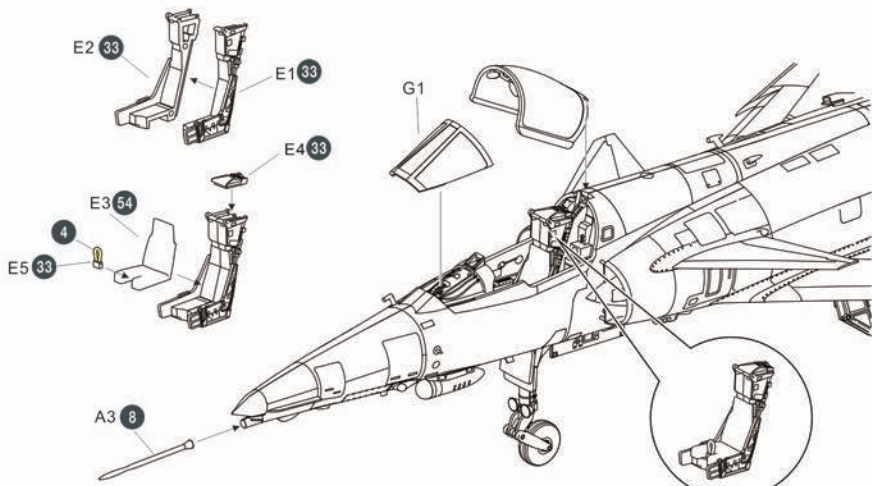

Mk. IN10LH ejection seat

19 C2 Weapons Configuration
C2 武器外掛裝配展示

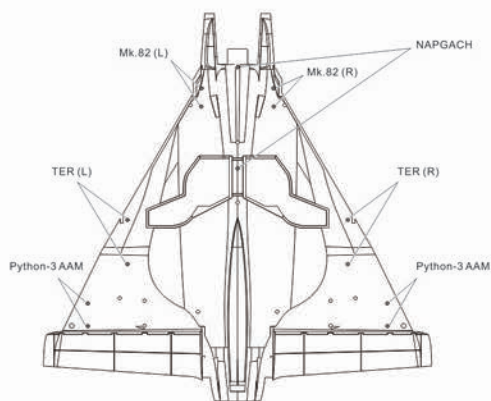
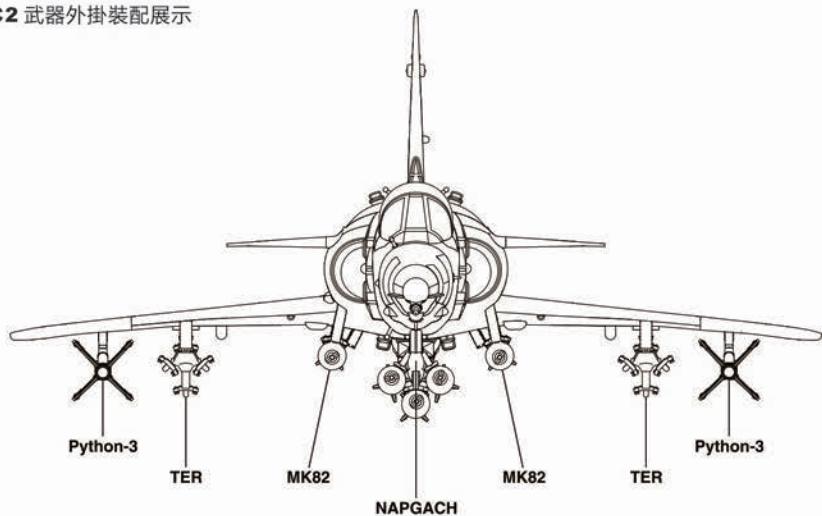

• Drill To Open
 鑽穿

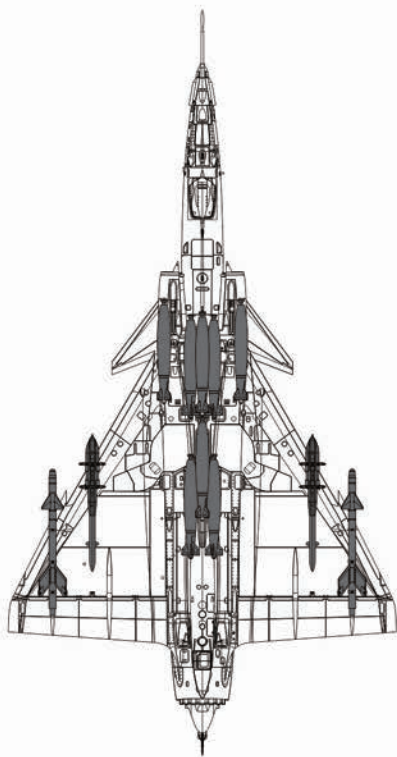

20 Attaching C2 Version Weapons C2版本武器装配

Python-3 AAM

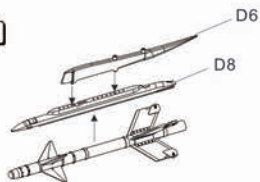

Mk.82

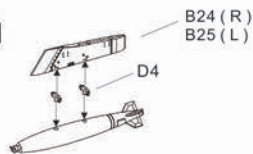

NAPGACH

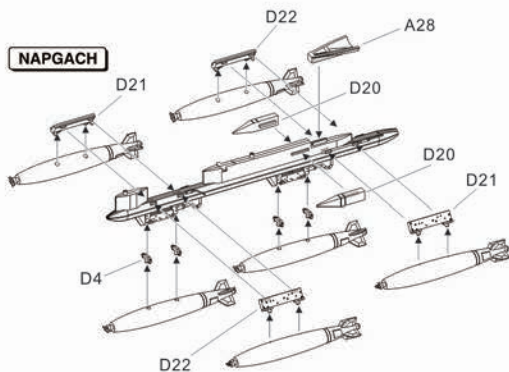

Wing pylon with TER

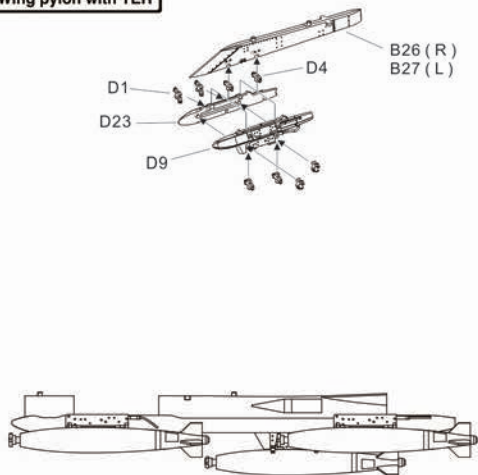

Painting and markings of external stores

- FS 35414 **20**
- FS 17038 **2**
- Steel **28**
- FS 17875 **1**
- FS 34151 **-12**

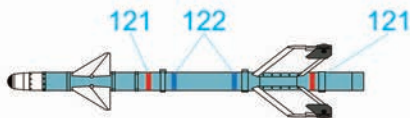

21 C7 Weapons Configuration

C7 武器外掛裝配展示

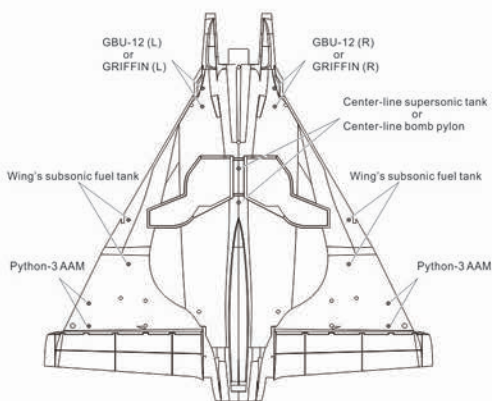
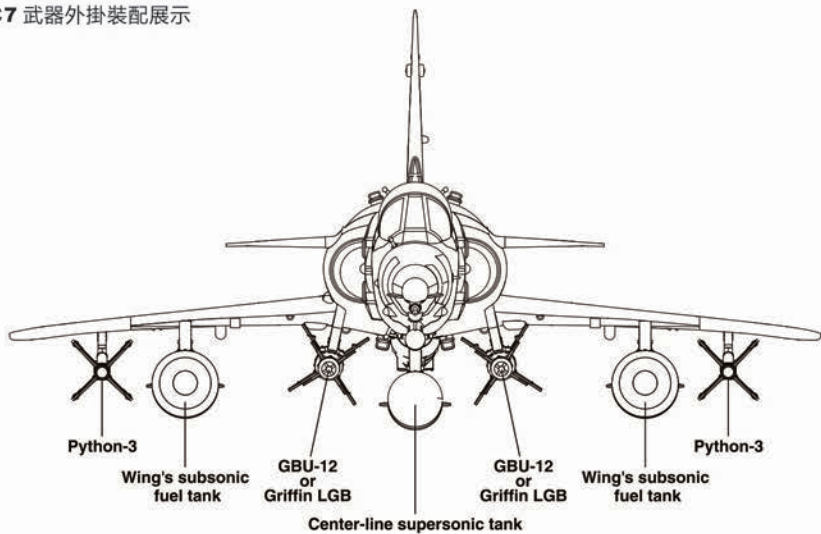

• Drill To Open
鑽穿

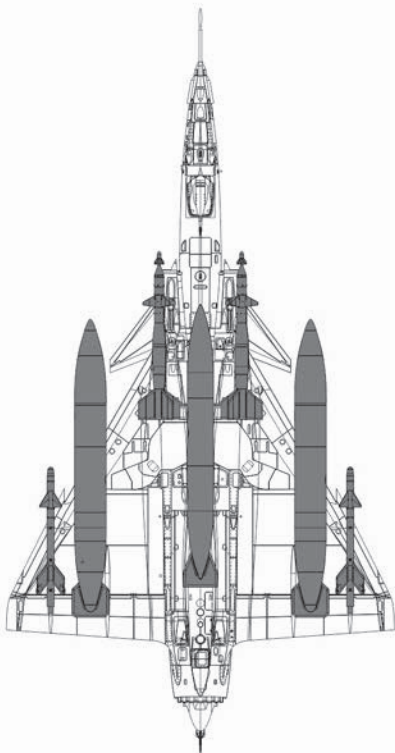

22 Attaching C7 Version Weapons C7版本武器装配

Python-3 AAM

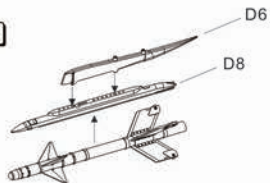

Center-line bomb pylon

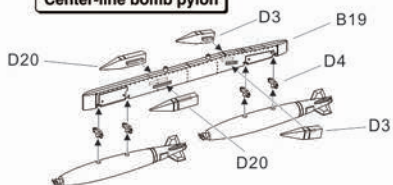

GBU-12

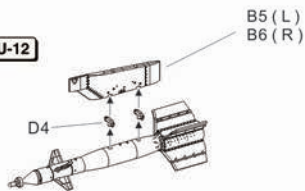

GRIFFIN

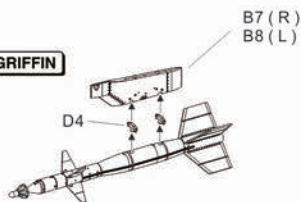

Center-line supersonic fuel tank

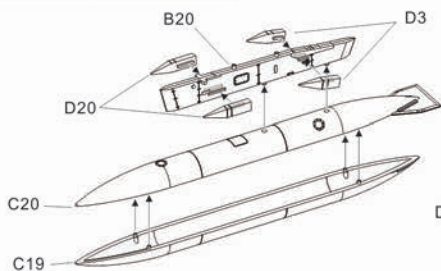

Wing's subsonic fuel tank

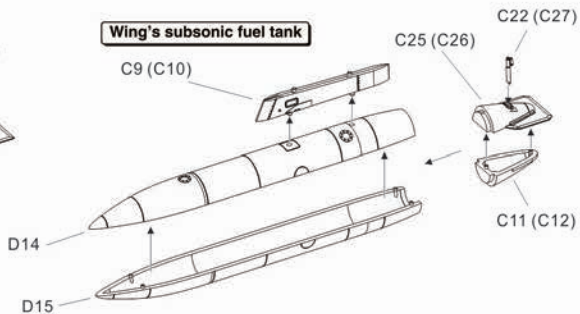

Painting and markings of external stores

	FS 36375	308
	FS 33531	313
	FS 30219	310
	FS 31302	4
	FS 35414	20
	FS 17038	2
	Steel	28
	FS 17875	1
	FS 34151	-12

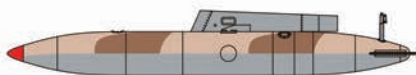
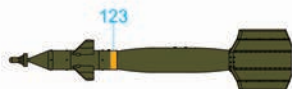
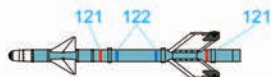

Kfir C7 #543 "Zohar", The Arava Guardians Squadron, Israeli AF 1990

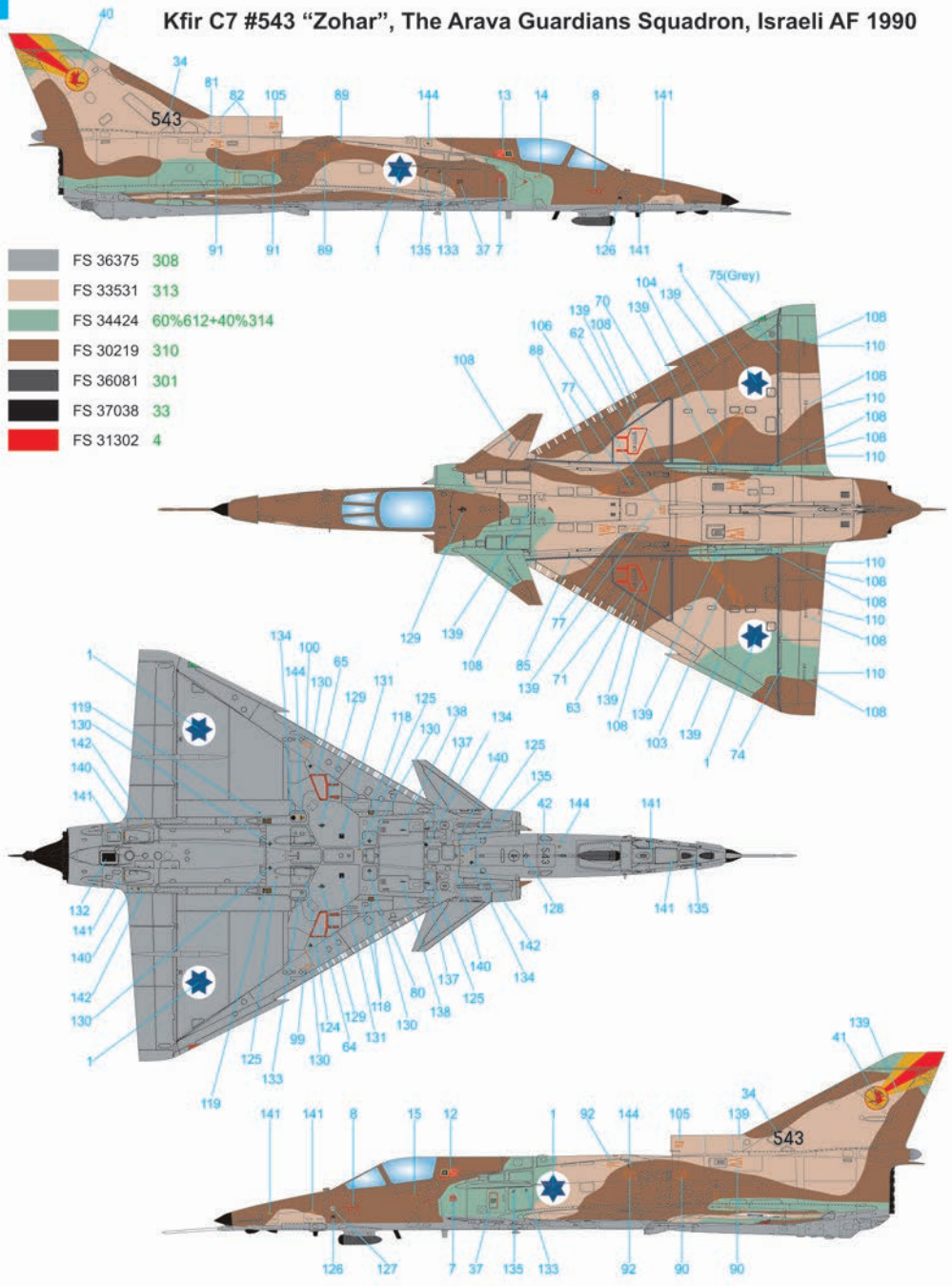

Kfir C2 N401AX, ATAC, U.S.A.

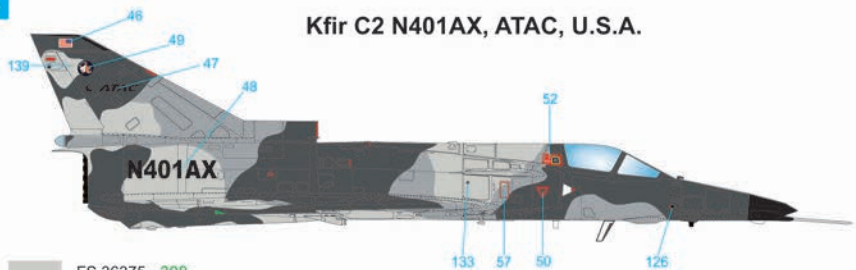

- FS 36375 308
- FS 36320 307
- FS 36118 305
- FS 37875 1
- FS 31302 4
- FS 37038 33

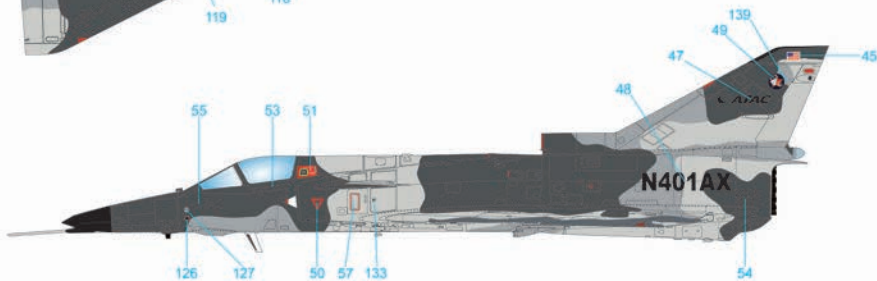
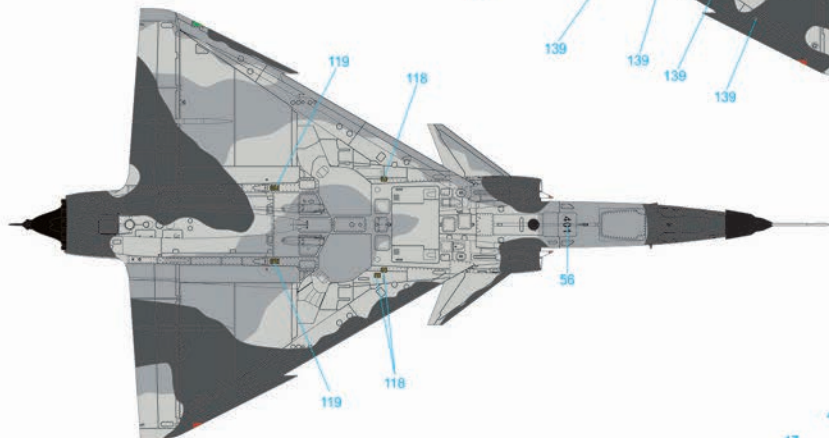
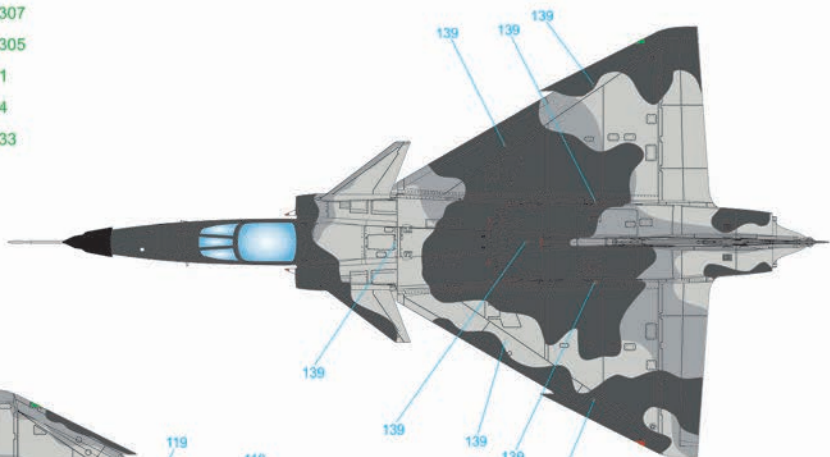

Kfir C2 FAE 905, 2113 Squadron, Ecuadorian AF 1998



- FS 36622 311
- FS 34258 -50% 39+ 50% 312
- FS 34079 309
- FS 37875 1
- FS 31302 4
- FS 37038 33

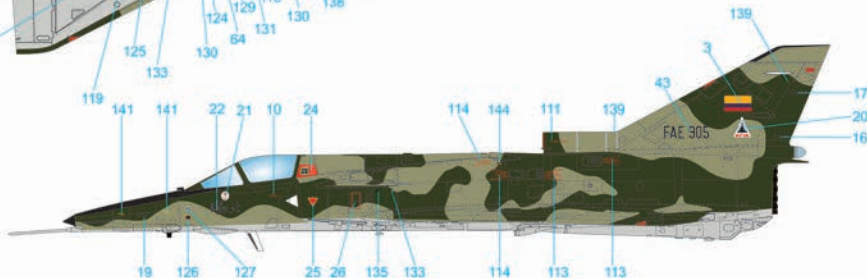
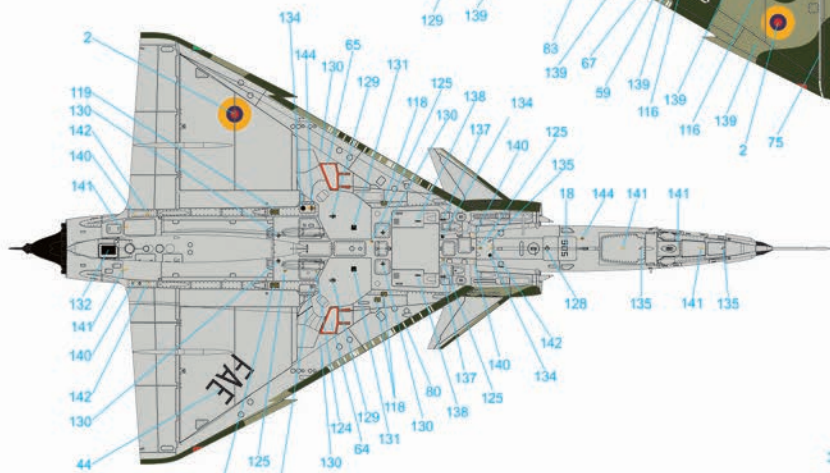
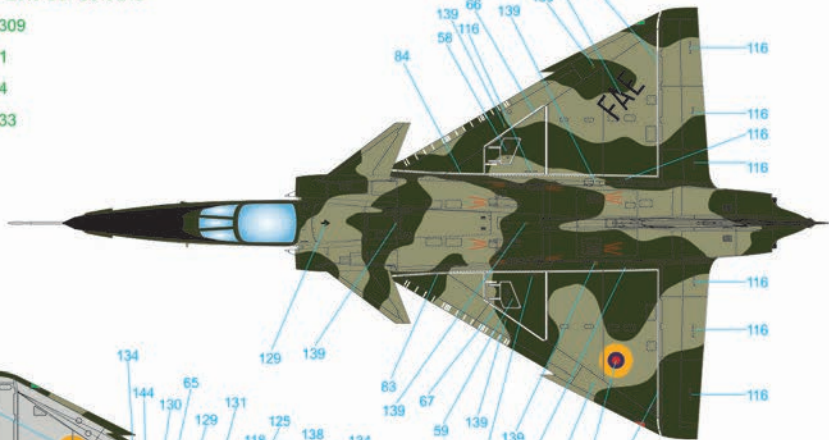

Kfir C7 FAC 3043, 111 Squadron, Colombian AF

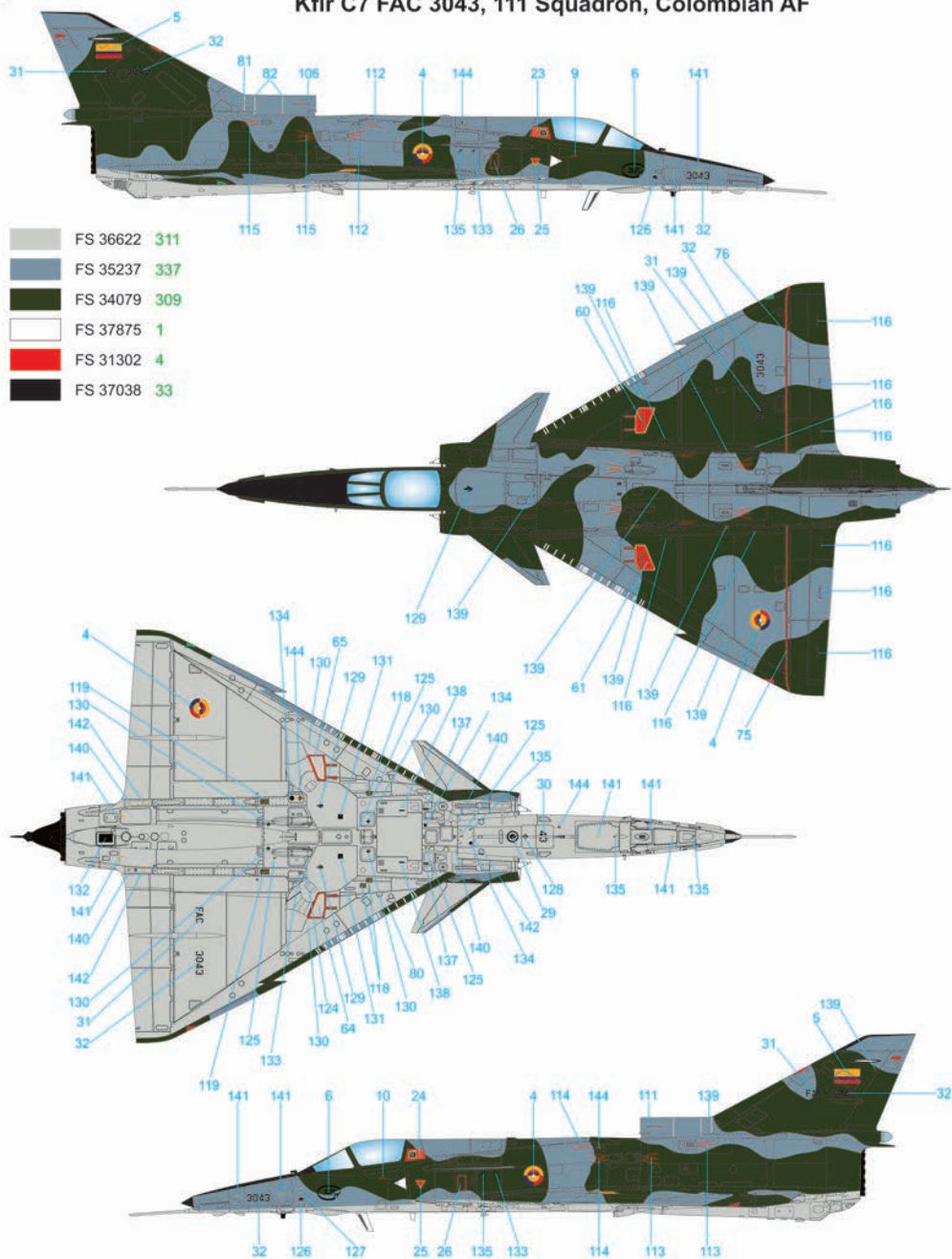

PARTS

A PARTS X 1
86B002-01

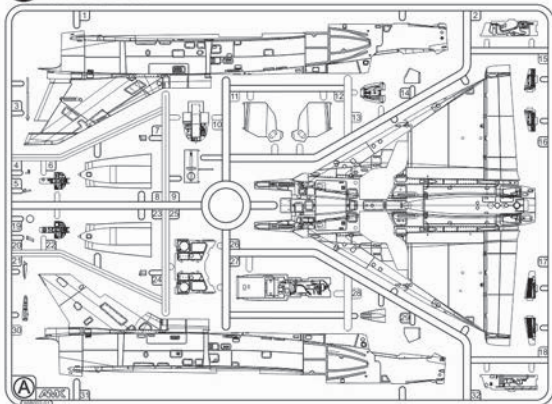

B PARTS X 1
86B002-02

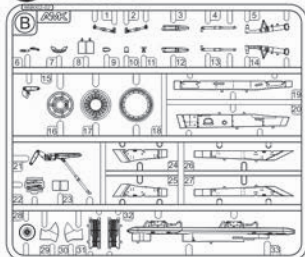

C PARTS X 1
86B002-03

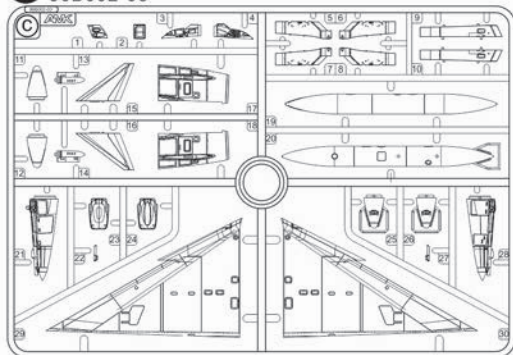

D PARTS X 2
86B002-04

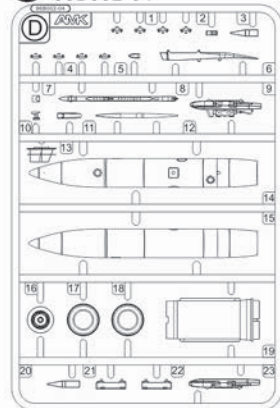

E PARTS X 1
86B002-05

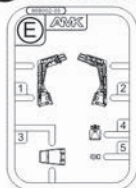

F PARTS X 1
86B002-06

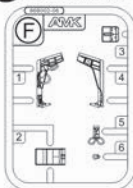

G PARTS X 1
86B002-07



AMK
AvantGarde Model Kits



AvantGarde Model Kits (AMK) Co., Ltd.

www.amkhobby.com

 AvantgardeModelKits



9 588325 720071

MADE IN CHINA

© Copyright 2016, AMK

1/72 SCALE

86002